

# AUTO-CRUISE CONTROL SYSTEM

## CONTENTS

110003802

<b>AUTO-CRUISE CONTROL SYSTEM*</b> .....	<b>28</b>	<b>SERVICE SPECIFICATIONS</b> .....	<b>3</b>
<b>GENERAL INFORMATION</b> .....	<b>2</b>	<b>SPECIAL TOOLS</b> .....	<b>3</b>
<b>SERVICE ADJUSTMENT PROCEDURES</b> ....	<b>21</b>	<b>TROUBLESHOOTING</b> .....	<b>4</b>
Auto-cruise Control Main Switch Inspection ...	22	Check Chart .....	8
Auto-cruise Control Switch Inspection .....	23	Diagnostic Output Inspection .....	17
Control Cable Inspection and Adjustment .....	21	Input Checking .....	19
Individual Parts Inspection .....	24	Preliminary Inspection .....	4
		Troubleshooting Quick Reference Chart .....	4

### WARNINGS REGARDING SERVICING OF SUPPLEMENTAL RESTRAINT SYSTEM (SRS) EQUIPPED VEHICLES

#### WARNING!

- (1) Improper service or maintenance of any component of the SRS, or any SRS-related component, can lead to personal injury or death to service personnel (from inadvertent firing of the air bag) or to the driver and passenger (from rendering the SRS inoperative).
- (2) Service or maintenance of any SRS component or SRS-related component must be performed only at an authorized MITSUBISHI dealer.
- (3) MITSUBISHI dealer personnel must thoroughly review this manual, and especially its GROUP 52B – Supplemental Restraint System (SRS) and GROUP 00 – Maintenance Service, before beginning any service or maintenance of any component of the SRS or any SRS-related component.

#### NOTE

The SRS includes the following components: SRS air bag control unit, SRS warning light, air bag module, clock spring and interconnecting wiring. Other SRS-related components (that may have to be removed/installed in connection with SRS service or maintenance) are indicated in the table of contents by an asterisk (\*).

## GENERAL INFORMATION

110003977

The auto-cruise control system has been adopted to drive the vehicle at constant speed desired by

the driver [approx. 40 km/h (25 mph) or more] without depressing the accelerator pedal.

## CONSTRUCTION DIAGRAMS

110003903

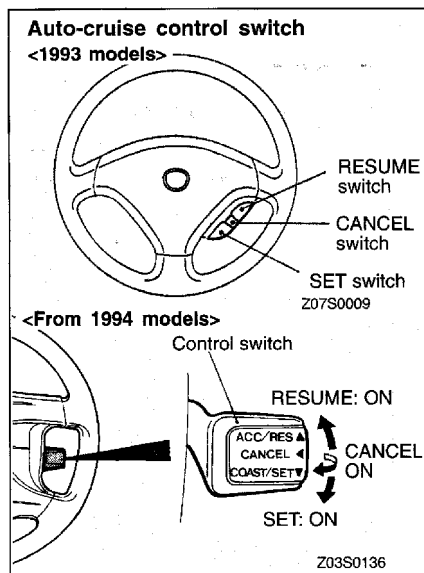
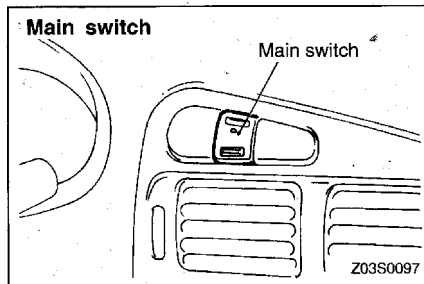
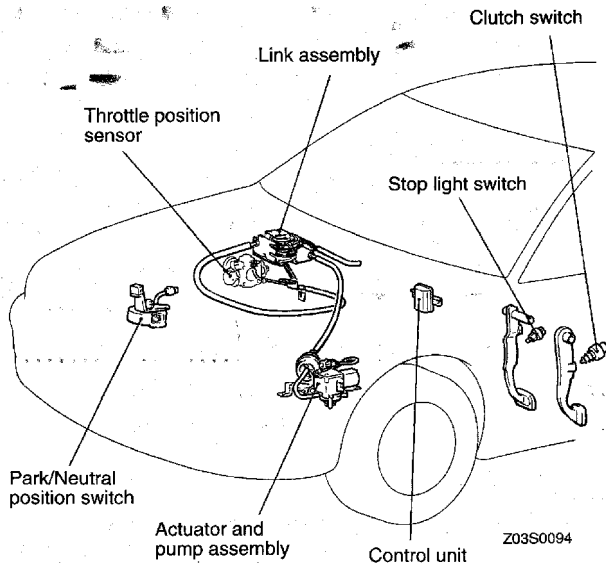





**SERVICE SPECIFICATIONS**

110003979

Items	Standard value	
Accelerator cable play mm (in.)	M/T	0-1 (0-.04)
	A/T	2-3 (.08-.12)
Throttle cable play mm (in.)	1-2 (.04-.08)	
Auto-cruise control cable play mm (in.)	1-2 (.04-.08)	
Resistance between terminals of control valve and relief valve in vacuum pump $\Omega$	50-60	

**SPECIAL TOOLS**

110003804

Tool	Tool number and name	Supersession	Application
	MB991341 Scan tool (Multi-use tester <MUT>)	MB991341C	1993 models Checking of the on-board diagnostic output
	ROM pack [ For the number, refer to GROUP 00 - Precautions before Service. ]		
	MB991502 Scan tool (MUT-II)	MB991502	All models Checking of the diagnosis code
	ROM pack		
	MB991529 Diagnostic trouble code check harness	MB991529	From 1994 models Checking of cruise control system when voltmeter is used

## TROUBLESHOOTING

### PRELIMINARY INSPECTION

Prior to troubleshooting, check the following parts. If there are defective ones, repair them.

- (1) Check that the vacuum pump assembly, link assembly, actuator, cables and vacuum hoses are properly installed and that the cables and hoses are correctly routed.

- (2) Check that the link assembly and all cables move smoothly.

- (3) Check each of the cables for excessive slackness or tension.

### TROUBLESHOOTING QUICK REFERENCE CHART

Auto-cruise control system is canceled when cancellation not wanted.  
Or, the auto-cruise control system cannot be set after an automatic cancellation.

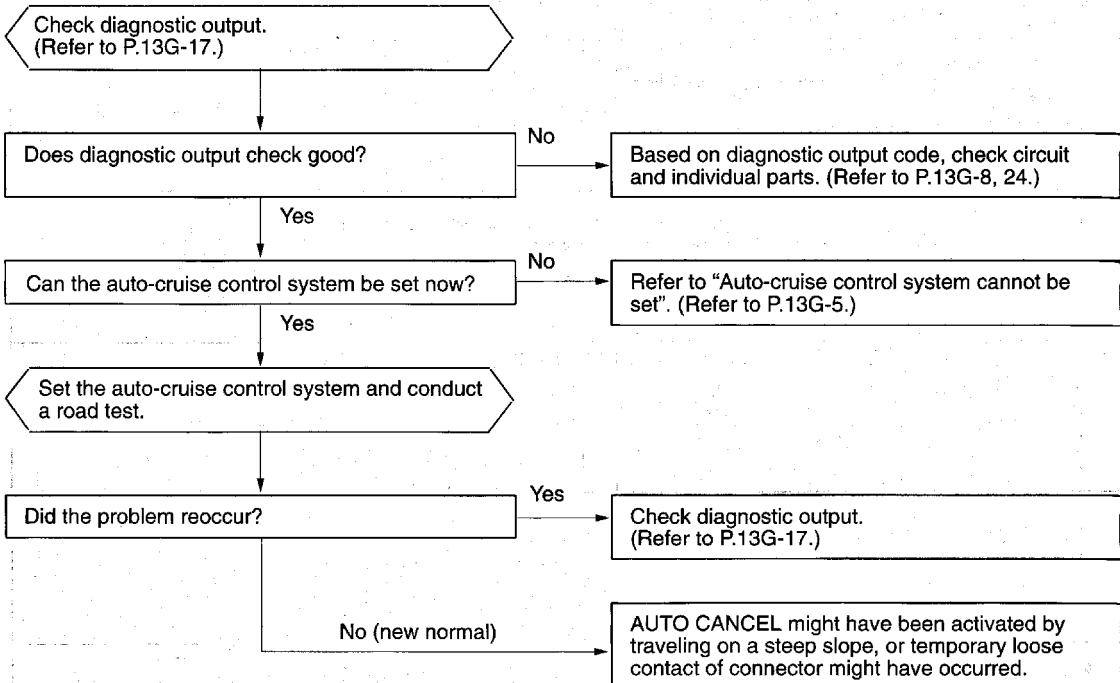

Auto-cruise control system cannot be set.

**NOTE**

This chart is to be used, then, for troubleshooting if it is not possible to use the on-board diagnostics for checking.

Prepare to conduct input check.  
(Refer to P.13G-19.)

Is the result of input check OK?

Yes

Check the auto-cruise vacuum pump circuit. (Go to check chart No.6.)

**NOTE**

If the auto-cruise vacuum pump circuit and the individual parts of the actuator check good, replace the auto-cruise control unit.

No

Check results	Probable cause	Remedy	Check chart No.
Even if an attempt is made to enter data, no code appears.	Open circuit in auto-cruise control unit power supply circuit	Replace control switch or repair harness.	No. 1
	Open circuit in control switch circuit		
	Defective auto-cruise control unit	Replace auto-cruise control unit.	
Code No. 21 remains even though SET switch is set to OFF.	SET switch ON malfunction	Replace the control switch.	No. 2
Code No. 22 remains even though RESUME switch is set to OFF.	RESUME switch ON malfunction	Replace the control switch.	No. 3
Code No. 23 does not appear when brake pedal is depressed.	Defective stop light switch circuit	Replace stop light switch or repair harness.	No. 7
Code No. 23 does not disappear when brake pedal is released.			
Code No. 26 does not disappear when clutch pedal is released. <M/T>	Defective clutch switch circuit	Replace clutch switch or repair harness.	No. 8
Code No. 26 does not disappear when SELECT lever is placed in a position other than "N" and "P". <A/T>	Defective Park/Neutral position switch circuit	Replace Park/Neutral position switch or repair harness.	No. 9
Code No. 25 does not appear when vehicle is traveling at less than 40 km/h (25 mph).	Defective vehicle speed sensor circuit	Check or repair vehicle speed sensor circuit.	No. 5
Code No. 25 does not disappear or code No. 24 does not appear when vehicle speed is increased to more than approximately 40 km/h (25 mph).			

Trouble symptom	Probable cause	Check chart No.	Remedy
<ul style="list-style-type: none"> <li>• The set vehicle speed varies greatly upward or downward.</li> <li>• "Hunting" (repeated alternating acceleration and deceleration) occurs after setting is made.</li> </ul>	Malfunction of the vehicle speed sensor circuit	No. 5	Repair the vehicle speed sensor system, or replace the part.
	Malfunction of the speedometer cable or speedometer drive gear		
	Auto-cruise vacuum pump circuit poor contact	No. 6	Repair the auto-cruise vacuum pump system, or replace the part.
	Malfunction of the auto-cruise vacuum pump		
	Malfunction of the auto-cruise control unit	–	Replace the auto-cruise control unit.
The auto-cruise control system is not canceled when the brake pedal is depressed.	Brake switch (for auto-cruise control) malfunction (short-circuit)	No. 7	Repair the harness or replace the stop light switch.
	Auto-cruise vacuum pump drive circuit short-circuit	No. 6	Repair the harness or replace the auto-cruise vacuum pump.
	Malfunction of the auto-cruise control unit	–	Replace the auto-cruise control unit.
The auto-cruise control system is not canceled when the clutch pedal is depressed. <M/T> (It is canceled, however, when the brake pedal is depressed.)	Damaged or disconnected wiring of clutch switch input circuit	If the input check code No. 26 indicates a malfunction. No. 8	Repair the harness, or repair or replace the clutch switch.
	Clutch switch improper installation (won't switch ON)		
	Malfunction of the auto-cruise control unit	–	Replace the auto-cruise control unit.
The auto-cruise control system is not canceled when the shift lever is moved to the "N" position. <A/T> (It is canceled, however, when the brake pedal is depressed.)	Damaged or disconnected wiring of Park/Neutral position switch input circuit	If the input check code No. 26 indicates a malfunction. No. 9	Repair the harness, or repair or replace the Park/Neutral position switch.
	Improper adjustment of Park/Neutral position switch		
	Malfunction of the auto-cruise control unit	–	Replace the auto-cruise control unit.

Trouble symptom	Probable cause	Check chart No.	Remedy
Cannot decelerate by using the SET switch.	Temporary damaged or disconnected wiring of SET switch input circuit	No. 2	Repair the harness or replace the SET switch.
	Auto-cruise vacuum pump circuit poor contact	No. 6	Repair the harness or replace the auto-cruise vacuum pump and actuator.
	Malfunction of the auto-cruise vacuum pump and actuator (including blocking of negative pressure passage)		
	Malfunction of the auto-cruise control unit	–	Replace the auto-cruise control unit.
Cannot accelerate or resume speed by using the RESUME switch.	Open or short circuit in RESUME switch circuit in control switch	No. 3	Replace the control switch.
	Auto-cruise vacuum pump circuit poor contact	No. 6	Repair the harness or replace the auto-cruise vacuum pump and actuator.
	Malfunction of the auto-cruise vacuum pump and actuator (including air leaks from negative pressure passage)		
	Malfunction of the auto-cruise control unit	–	Replace the auto-cruise control unit.
Auto-cruise control system can be set while traveling at a vehicle speed of less than 40 km/h (25 mph), or there is no automatic cancellation at that speed.	Malfunction of the vehicle speed sensor circuit	No. 5	Repair the vehicle speed sensor system, or replace the part.
	Malfunction of the speedometer cable or the speedometer drive gear		
	Malfunction of the auto-cruise control unit	–	Replace the auto-cruise control unit.
The auto-cruise control main switch indicator light does not illuminate. (But auto-cruise control system is normal.)	Damaged or disconnected bulb of auto-cruise control main switch indicator	No. 4	Repair the harness or replace the main switch.
	Harness damaged or disconnected		
Overdrive is not canceled during fixed speed driving. <A/T>	Malfunction of circuit related to overdrive cancellation, or malfunction of auto-cruise control unit	No. 10	Repair the harness or replace the part.
No shift to overdrive during manual driving. <A/T>			
The auto-cruise control indicator light does not illuminate. (But auto-cruise control system is normal.)	Damaged or disconnected bulb of indicator light	No. 4	Repair the harness or replace the bulb.
	Harness damaged or disconnected		

## CHECK CHART

## 1 Inspection of control unit power supply circuit

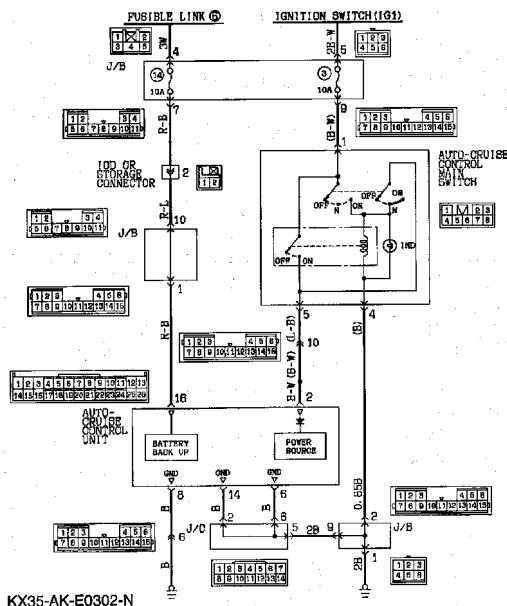

## DESCRIPTION OF OPERATION

When the auto-cruise control switch is set to ON with the ignition placed at the ON position, the current flows from the ignition switch (IG<sub>1</sub>) to the fuse No. 3 of junction block, the auto-cruise control main switch, the auto-cruise control unit and ground.

When the ignition switch is placed at the OFF position, the auto-cruise control main switch is set to OFF at the same time.

## TROUBLESHOOTING HINTS

## ECU terminal voltage

Terminal No.	Signal name	Condition	Terminal voltage
2	Control unit power supply	Main switch ON and neutral position thereafter	B+
		Main switch OFF and neutral position thereafter	0V
6, 8, 14	Control unit ground	At all times	0V
16	Control unit back up power supply	At all times	B+

2 Inspection of control switch circuit <1993 models>

DESCRIPTION OF OPERATION

The control switch is a switch in which the SET, RESUME and CANCEL switches are integrated. Therefore, different resistance values are used for the individual switches to change the outputs (voltages) to the control unit. Current flows through fuse No. 5 of J/B and through the control switch to the control unit.

1. SET switch

When the auto-cruise control switch is ON, if the SET switch is set to ON while vehicle speed is within a range from about 40 to 200 km/h (25 to 124 mph), the vehicle starts cruising at the speed. If the SET switch is kept at ON during cruise operation, the vehicle coasts, and starts cruising at the speed reached when the SET switch is set to OFF.

2. RESUME switch

Even if cruise operation is canceled, the vehicle resumes cruising at the speed set before the cancellation. Both when the main switch is set to OFF and when the vehicle speed is reduced to less than 40 km/h (25 mph), the vehicle will not resume cruising at the previously set speed even if the RESUME switch is set to ON. If the RESUME switch is kept at ON during cruise operation, the engine accelerates, and the vehicle starts cruising at the speed reached when the RESUME switch was set to OFF.

3. CANCEL switch

When the CANCEL switch is set to ON during cruise operation, the cancel signal is input to the control unit which internally interrupts the power supply to the vacuum pump assembly for cancellation of cruise operation.

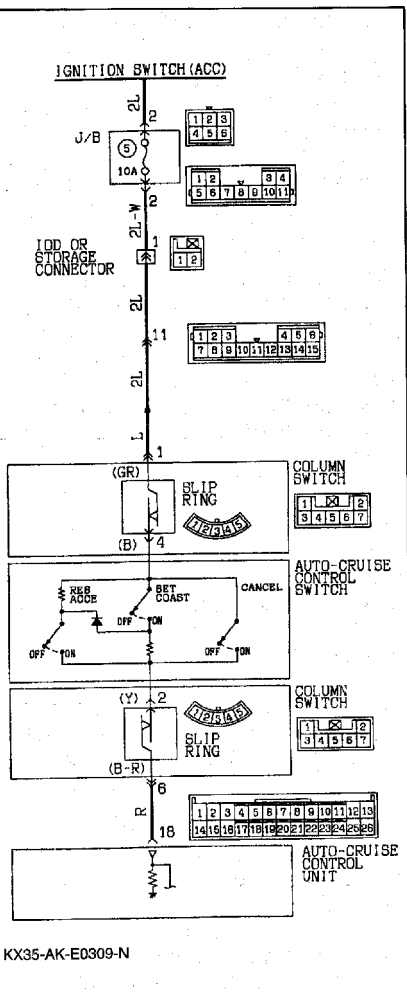

KX35-AK-E0309-N

TROUBLESHOOTING HINTS

Diagnosis No. 15 (Automatically canceled)

ECU terminal voltage

Terminal No.	Signal name	Condition	Terminal voltage
18	Control switch	When all switches are OFF	0V
		When SET switch is ON	3V
		When RESUME switch is ON	6V
		When CANCEL switch is ON	B+

## 2 Inspection of control switch circuit <From 1994 models>

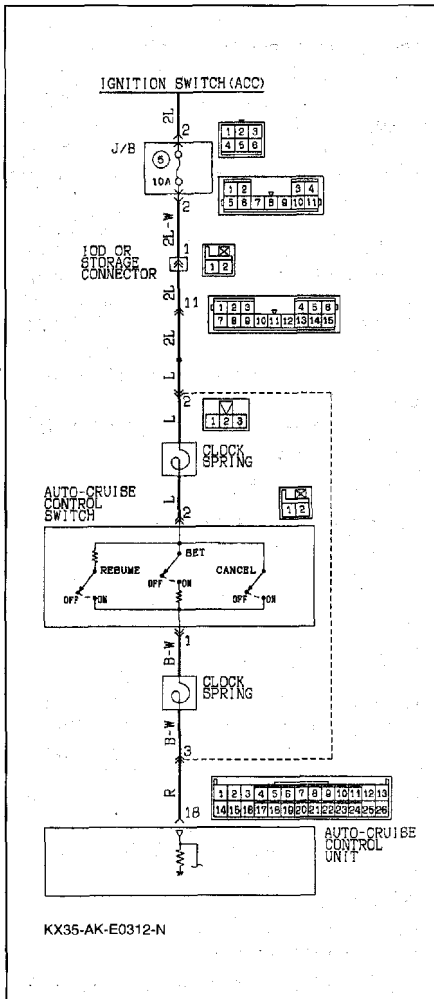

### DESCRIPTION OF OPERATION

The control switch is a switch in which the SET, RESUME and CANCEL switches are integrated. Therefore, different resistance values are used for the individual switches to change the outputs (voltages) to the control unit. Current flows through fuse No. 5 of J/B and through the control switch to the control unit.

#### 1. SET switch

When the auto-cruise control switch is ON, if the SET switch is set to ON while vehicle speed is within a range from about 40 to 200 km/h (25 to 124 mph), the vehicle starts cruising at the speed. If the SET switch is kept at ON during cruise operation, the vehicle coasts, and starts cruising at the speed reached when the SET switch is set to OFF.

#### 2. RESUME switch

Even if cruise operation is canceled, the vehicle resumes cruising at the speed set before the cancellation. Both when the main switch is set to OFF and when the vehicle speed is reduced to less than 40 km/h (25 mph), the vehicle will not resume cruising at the previously set speed even if the RESUME switch is set to ON. If the RESUME switch is kept at ON during cruise operation, the engine accelerates, and the vehicle starts cruising at the speed reached when the RESUME switch was set to OFF.

#### 3. CANCEL switch

When the CANCEL switch is set to ON during cruise operation, the cancel signal is input to the control unit which internally interrupts the power supply to the vacuum pump assembly for cancellation of cruise operation.

### TROUBLESHOOTING HINTS

#### Diagnosis No. 15 (Automatically canceled)

#### ECU terminal voltage

Terminal No.	Signal name	Condition	Terminal voltage
18	Control switch	When all switches are OFF	0V
		When SET switch is ON	3V
		When RESUME switch is ON	6V
		When CANCEL switch is ON	B+

3 Inspection of indicator light circuit

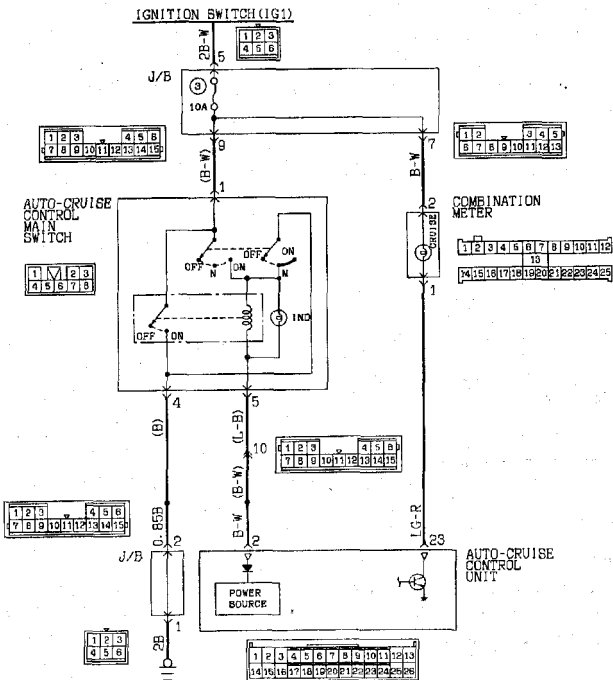

KX35-AK-E0301-N

DESCRIPTION OF OPERATION

1. Auto-cruise control main switch indicator light

It lights as soon as the main switch is set to ON.

2. Auto-cruise control (CRUISE) indicator light

During cruise control operation, transistor Tr<sub>1</sub> in the control unit is kept in the ON state to keep the indicator light on.

TROUBLESHOOTING HINTS

ECU terminal voltage

Terminal No.	Signal name	Condition	Terminal voltage
23	Auto-cruise control (CRUISE) indicator light	When cruise control is active	0V
		When cruise control is inactive	B+

## 4 Inspection of vehicle speed sensor circuit

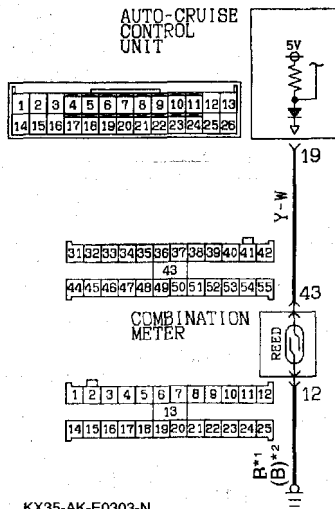

## NOTE

\*1: 1993 models

\*2: From 1994 models

## DESCRIPTION OF OPERATION

The vehicle speed sensor is a reed switch type and is mounted in the speedometer. It sends pulse signals proportional to the rotational speed of the

transmission output gear (vehicle speed) to the control unit. (Four pulse signals generated per rotation of the output gear)

## TROUBLESHOOTING HINTS

## Diagnosis No. 12 (Automatically canceled)

## ECU terminal voltage

Terminal No.	Signal name	Condition	Terminal voltage
19	Vehicle speed sensor	Slowly drive forward with SELECT lever at "D" or "1st Speed"	0 to 0.6V ↔ 2V or more (Flashing)

5 Inspection of vacuum pump assembly drive circuit

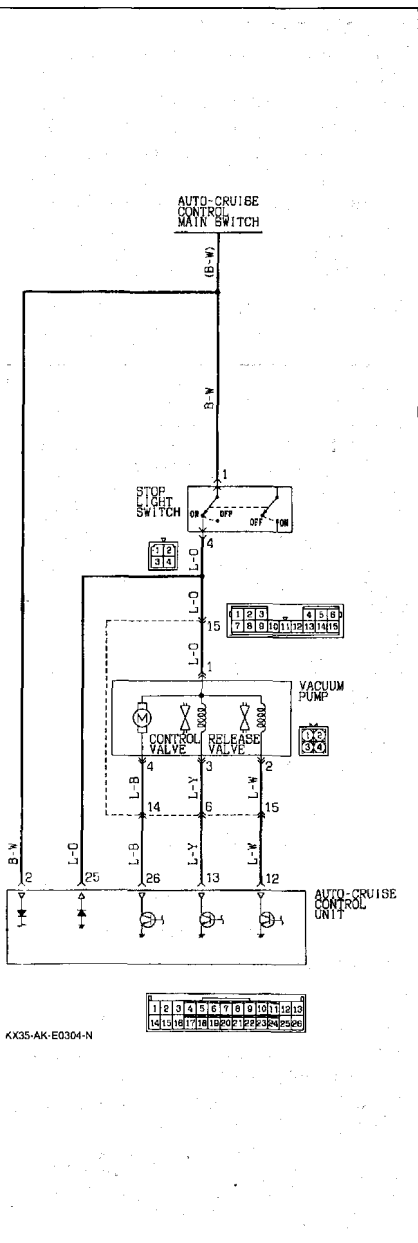

DESCRIPTION OF OPERATION

The vacuum pump assembly consists of a diaphragm type negative pressure pump that is driven by a DC motor, and two solenoid valves (control valve and release valve) and is controlled by the control unit as shown in the following table. When the brake pedal is depressed during cruise control operation, the power supply to the vacuum pump assembly is cut off.

Cruise control operation	DC motor (ON: Current flows) (OFF: No current flows)	Control valve (ON: open) (OFF: closed)	Release valve (ON: open) (OFF: closed)
Acceleration	ON	ON	ON
Hold	OFF	ON	ON
Deceleration	OFF	OFF	ON
Release	OFF	OFF	OFF

TROUBLESHOOTING HINTS

Diagnosis No. 11 (Automatically canceled)

ECU terminal voltage

Terminal No.	Signal name	Condition	Terminal voltage
12	Release valve drive signal	When release valve is ON	0V
		When release valve is OFF	B+
13	Control valve drive signal	When control valve is ON	0V
		When control valve is OFF	B+
26	DC motor drive signal	When DC motor is running	0V
		When DC motor is stationary	B+
25	Surge absorption circuit terminal	When main switch is ON	B+

6 Inspection of stop light switch circuit

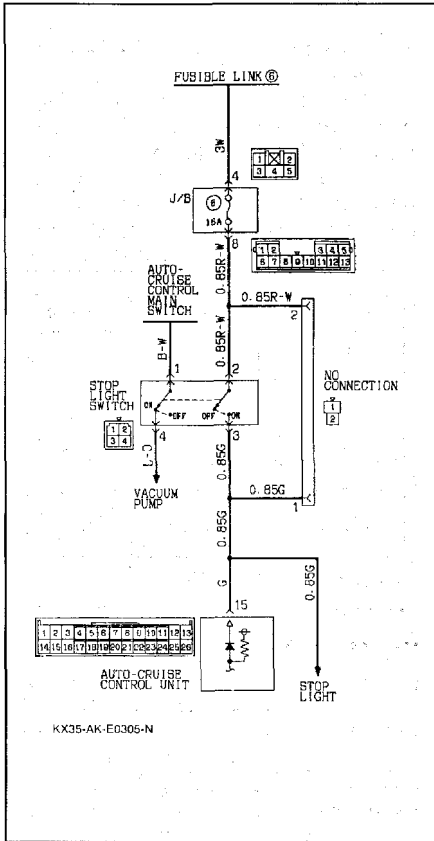

DESCRIPTION OF OPERATION

When the brake pedal is depressed during vehicle speed control, the cruise control (NC) contact of the stop light switch is opened to interrupt the power supply to the vacuum pump assembly for cancellation of vehicle speed control. (Refer to P.13G-13.) At the same time, the stop light (NO) contact is closed. As a result, a cancel signal is input to the control unit which internally interrupts the vacuum pump assembly drive circuit.

TROUBLESHOOTING HINTS

ECU terminal voltage

Terminal No.	Signal name	Condition	Terminal voltage
15	Stop light switch	When brake pedal is depressed	B+
		When brake pedal is not depressed	0V

7 Inspection of clutch switch circuit <M/T>

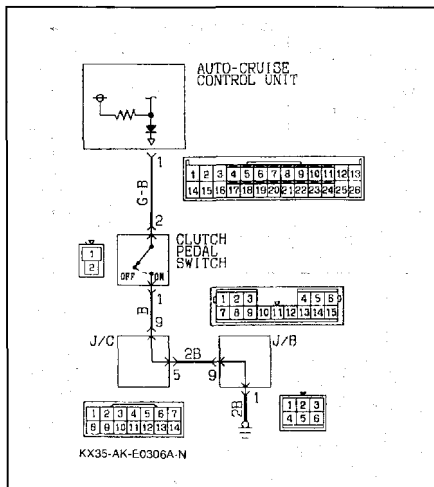

DESCRIPTION OF OPERATION

When the clutch pedal is depressed during vehicle speed control, the contact of the clutch switch is closed. As a result, a cancel signal is input to the control unit which internally interrupts the power supply to the vacuum pump assembly drive circuit for cancellation of vehicle speed control.

TROUBLESHOOTING HINTS

ECU terminal voltage

Terminal No.	Signal name	Condition	Terminal voltage
1	Clutch switch	When clutch pedal is depressed	0V
		When clutch pedal is not depressed	B+

**8 Inspection of Park/Neutral position switch circuit <A/T>**

**DESCRIPTION OF OPERATION**

The Park/Neutral position switch is interlocked with the starter switch. When the gear selector lever is placed in the “N” position during vehicle speed control, a cancel signal is input to the control unit which internally interrupts the power supply to the vacuum pump assembly drive circuit for cancellation of vehicle speed.

**TROUBLESHOOTING HINTS**

**ECU terminal voltage**

Terminal No.	Signal name	Condition	Terminal voltage
1	Park/Neutral position switch	Park/Neutral position switch in “N” or “P” position	0V
		Park/Neutral position switch in “D”, “2”, “L” or “R” position	B+

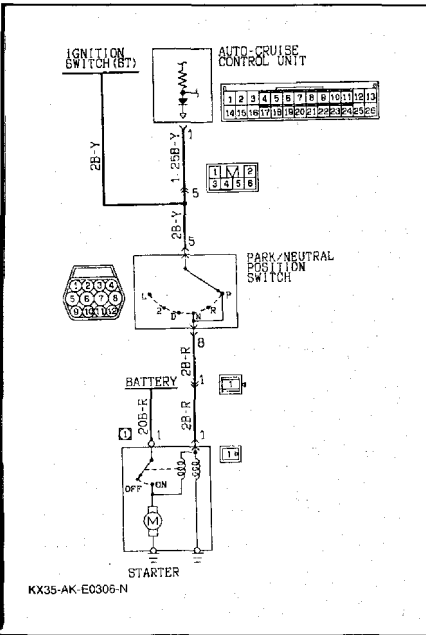

KX35-AK-E0306-N

**9 Inspection of throttle position sensor circuit**

**DESCRIPTION OF OPERATION**

The throttle position sensor (with built-in closed throttle position switch) is used for engine control as well as cruise control.

The throttle position sensor sends data to the control unit, regarding the opening of the accelerator. The closed throttle position switch inputs the data to the control unit on whether or not the accelerator pedal is operated.

**TROUBLESHOOTING HINTS**

**Diagnosis No. 17 (Not automatically canceled)**

**ECU terminal voltage**

Terminal No.	Signal name	Condition	Terminal voltage
4	Closed throttle position switch	When accelerator pedal is depressed	0V
		When accelerator pedal is not depressed	4.5–5.5V
5	Throttle position sensor	During idle	0.48–0.72V
		When fully opened	4.0–5.5V

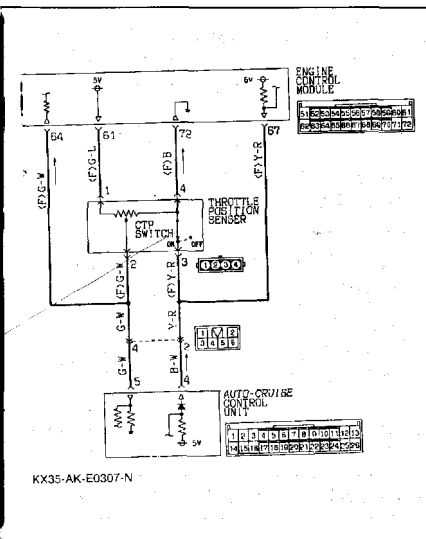

KX35-AK-E0307-N

10 Inspection of circuits associated with overdrive cancel <A/T>

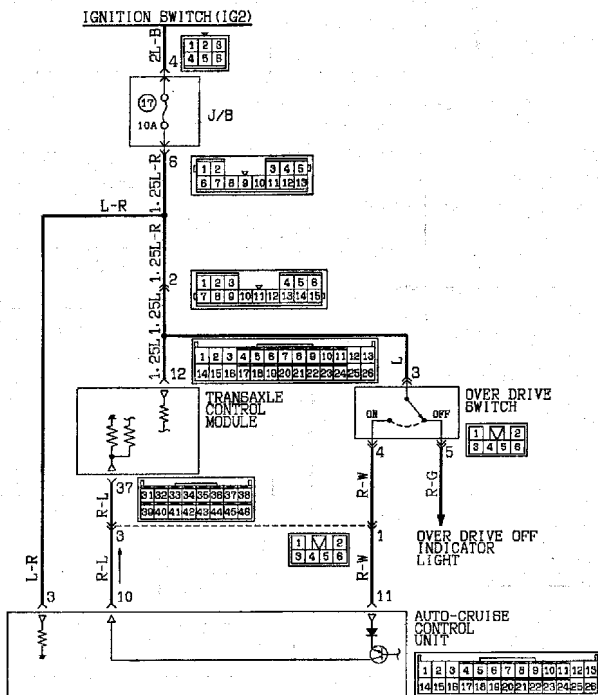

KX35-AK-E0308-N

DESCRIPTION OF OPERATION

On a vehicle with cruise control, the OD switch ON signal is input through the cruise control unit to the ELC-4A/T control module.

When the vehicle speed control is in the overdrive mode, if the actual vehicle speed falls more than about 7 km/h (4 mph) below the set vehicle speed

or the RESUME switch is turned ON, the cruise control unit forces transistor Tr<sub>1</sub> into the OFF state. This cancels the overdrive mode because no OD switch ON signal is input to the ELC-4A/T control module.

TROUBLESHOOTING HINTS

ECU terminal voltage

Terminal No.	Signal name	Condition	Terminal voltage
3	OD signal control power supply	When ignition switch is ON	B+
10	ELC-4A/T control module	When overdrive mode is active	B+
		When overdrive mode is inactive	0V
11	OD switch	When OD switch is ON	B+
		When OD switch is OFF	0V

**DIAGNOSTIC OUTPUT INSPECTION**

Inspection of diagnosis is performed when automatic cancellation occurs during auto-cruise control without cancellation mode by the driver.

**WHEN USING THE SCAN TOOL [MULTI-USE TESTER (MUT) <1993 models> OR MUT-II <All models>]**

1. Connect the scan tool (MUT-II) to the data-link connector. When connecting the scan tool (MUT-II) to a 1993 model vehicle, use the adapter harness supplied together.

**Caution**

**Turn the ignition switch off before connecting or disconnecting the scan tool.**

2. Compare the read output code with the chart below to find the cause systematically.
3. If the diagnostic trouble code No. is displayed, check in accordance with the inspection chart No. corresponding to each code No.

**NOTE**

In order to permit of checking if the trouble occurred in the past, the diagnostic trouble code remains in memory until the cable is disconnected from the battery terminal even if the ignition key is placed in the OFF position.

The diagnostic trouble code can also be erased by the following method.

- (1) Place the ignition switch in the ON position.
- (2) With the SET switch in the ON position, set the main switch to the ON position. Within 1.0 seconds from this operation, place the RESUME switch in the ON position.
- (3) With the SET switch placed in the ON position again, keep the stop light switch in the ON position for more than five seconds.
- (4) Turn off the main switch once and turn it on again.
- (5) Check the diagnostic trouble code to see if the normal code is output.

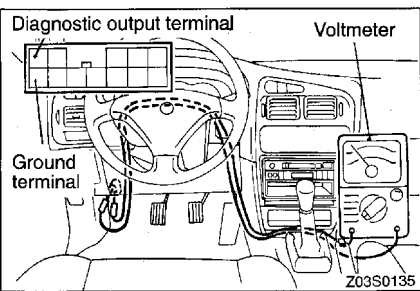
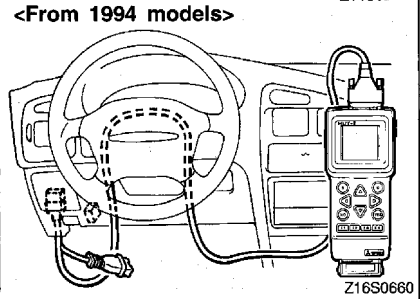
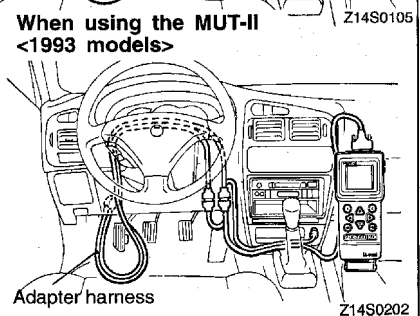
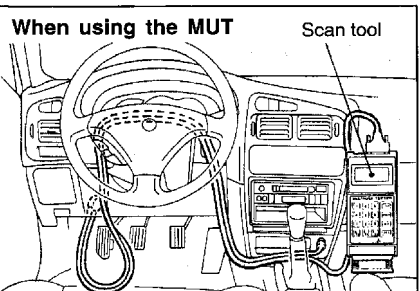

**WHEN USING THE VOLTMETER <1993 models>**

1. Connect an analog voltmeter across the diagnostic output terminal and ground terminal of the data link connector.
2. Place the ignition switch and main switch in the ON position.
3. Read the diagnostic trouble code on the basis of the deflection of the pointer of the voltmeter.
4. Refer to the diagnostic chart and repair the defective point.
5. Clear the diagnostic trouble codes in the same way as when a scan tool is used.

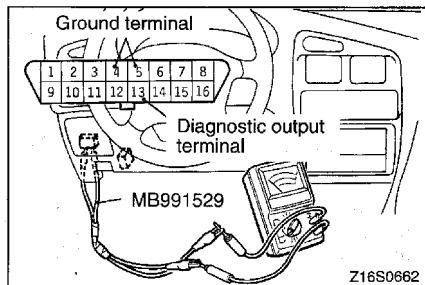

## &lt;From 1994 models&gt;

Using the special tool, connect a voltmeter to the diagnostic output and ground terminals of the data-link connector, and read the diagnostic trouble code on the basis of the deflection of the pointer.

## DIAGNOSIS DISPLAY PATTERNS AND CODES

Code No.	Display patterns (output codes) (Use with voltmeter)	Probable cause	Check chart No.
11	 The same pattern repeatedly displayed Y12A0104	Vacuum pump assembly drive output system out of order	5
12	 V12A0104	Vehicle speed signal system out of order	4
15	 U12A0104	Control switch out of order (When SET or RESUME switch is kept in ON state continuously for more than 60 seconds)	2
16	 T12A0104	Control unit out of order	-
17*	 S12A0104	Throttle position sensor or idle switch out of order	9

Normal code



R12A0104

## NOTE

1. The diagnostic trouble code is displayed when the vehicle is driven with the main switch on but not at the constant speed.
2. Even if the problem represented by the code number marked \* occurs during cruise control operation, the cruise control mode will not be canceled.
3. After erasing diagnostic trouble code memory, turn on the control unit power supply again, and the on-board diagnostic output code displayed will be "NORMAL!!" or the pattern shown in the illustration at left, regardless of whether the system is in normal or abnormal if the control unit power supply is normal.

**INPUT CHECKING**

Input checks should be made when the cruise control system cannot be set and when it is necessary to check (when a malfunction related to the cruise control system occurs) whether or not the input signals are normal.

**NOTE**

1. Input check can be conducted by set operations. On-board diagnostic terminal outputs display patterns.
2. Display codes are displayed only if the circuit is normal according to the conditions shown in the table on the next page.

Perform checks using the following procedures.

1. Connect a voltmeter to the data-link connector of the junction block.

2. Calling up a code
  - (1) Set the ignition switch to ON.
  - (2) With the SET switch in the ON state, set the main switch to ON. In less than 1.0 second thereafter, set the RESUME switch to ON. Then the input check results can be displayed.

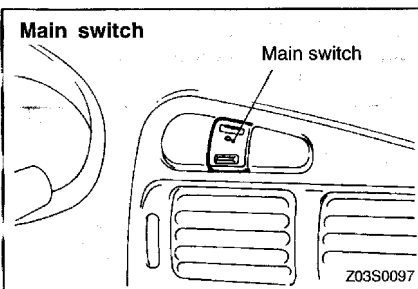
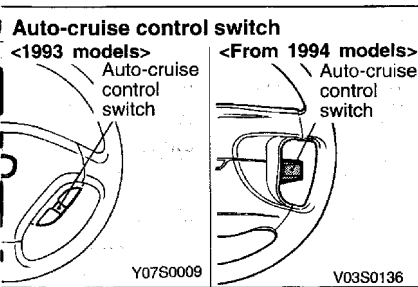







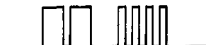

3. Reading a code
  - (1) Perform the individual input operations according to the input check table and read the codes.

**NOTE**

1. When two or more input operations are performed simultaneously, all the associated code numbers are output in ascending order.
2. If no code is output by performing any of the input operations, the control unit power supply circuit or SET and RESUME switches are probably defective. Check the check chart 1 and 2 (P.13G-8, 9).

## INPUT CHECK TABLE

Code No.	Display patterns (output codes) (Use with voltmeter)	Input operation		Check results
21	 Z12A0107	SET switch ON		SET switch circuit normal
22	 Y12A0107	RESUME switch ON		RESUME switch normal
23	 X12A0107	Stop light switch ON (brake pedal depressed)		Stop light switch circuit normal
24	 W12A0107	Vehicle speed more than approx. 40 km/h (25 mph)		Vehicle speed sensor circuit normal if code Nos. 24 and 25 are displayed
25	 P12A0107	Vehicle speed less than approx. 40 km/h (25 mph)		
26	 O12A0107	M/T	Clutch switch ON (clutch pedal depressed)	Clutch switch circuit normal
		A/T	Park/Neutral position switch ON (SELECT lever placed in "N" position)	Park/Neutral position switch circuit normal
27	 N12A0107	CANCEL switch ON		CANCEL switch circuit normal
28	 M12A0107	TPS output voltage 1.5 V or more (Accelerator pedal depressed more than half the way)		Throttle position sensor circuit normal
29	 L12A0107	Closed throttle position switch OFF (Accelerator pedal depressed)		Closed throttle position switch circuit normal

**SERVICE ADJUSTMENT PROCEDURES**

**CONTROL CABLE INSPECTION AND ADJUSTMENT**

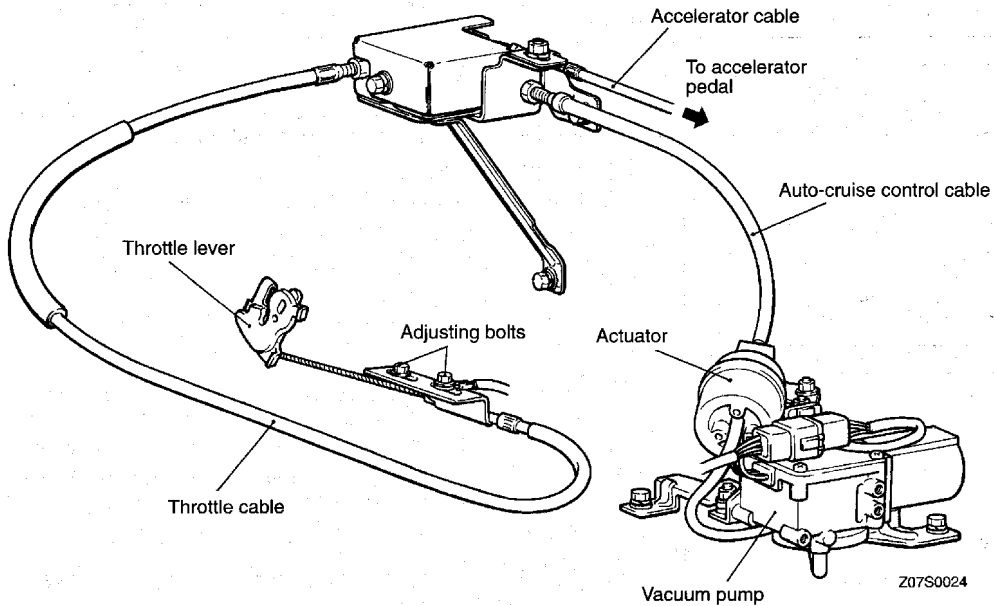

**CABLES INSPECTION**

- (1) Remove the link protector. (Refer to P.13G-28.)
- (2) Check the accelerator cable, auto-cruise control cable and throttle cable for slack in their inner cables. If there is excessive slack or no play in the inner cable, loosen the adjusting bolt in each link to free the throttle lever and each link. (Do not remove each nut.)

## ACCELERATOR CABLE ADJUSTMENT

110003983

1. With the link A held against the stopper, loosen the adjusting nut and slide the plate of the accelerator cable to adjust the accelerator cable play to the nominal value.

### Nominal value:

0–1 mm (0–.04 in.) <M/T>

2–3 mm (.08–.12 in.) <A/T>

2. After adjustment, tighten the adjusting nut positively to secure the cable.

## THROTTLE CABLE ADJUSTMENT

110003984

1. With the link B held in light contact with the link A, adjust throttle cable play to the nominal value by means of the adjusting nut.

**Nominal value: 1–2 mm (.04–.08 in.)**

2. After adjustment, secure the cable with the lock nut.

## AUTO-CRUISE CONTROL CABLE ADJUSTMENT

110003985

1. With the link C held in light contact with the link B, adjust auto-cruise control cable play to the nominal value by means of the adjusting nut.

**Nominal value: 1–2 mm (.04–.08 in.)**

2. After adjustment, secure the cable with the lock nut.

## AUTO-CRUISE CONTROL MAIN SWITCH INSPECTION

110003986

1. Place the ignition switch in the ON position.
2. Make sure that when the main switch is set to the ON position, the indicator light inside the switch comes on.

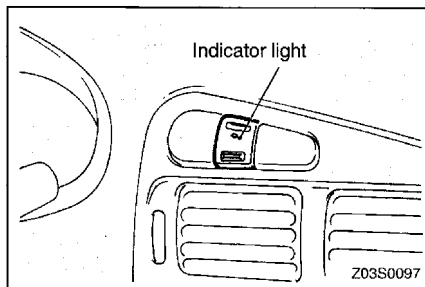
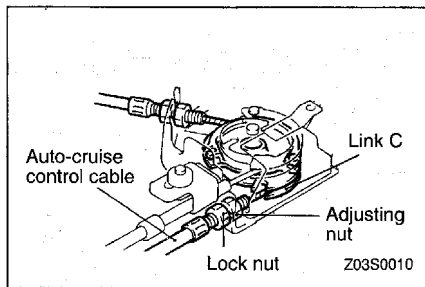
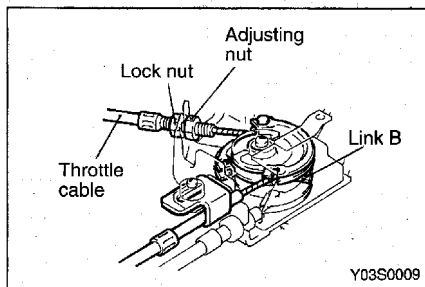
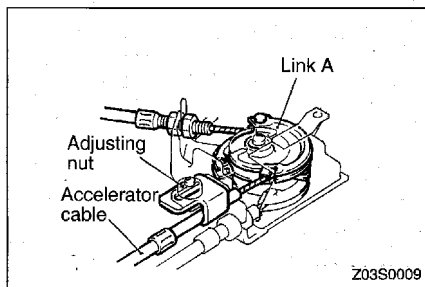

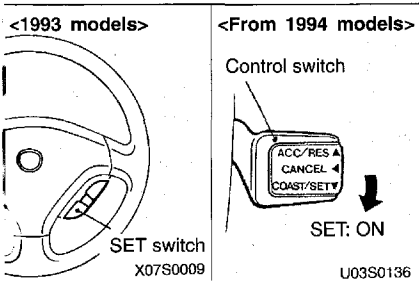

**AUTO-CRUISE CONTROL SWITCH INSPECTION**

110003806

**AUTO-CRUISE CONTROL SETTING CHECK**

1. Switch ON the main switch.
2. Drive at the desired speed within the range of more than approximately 40 km/h (25 mph).
3. Press the SET switch <1993 models> or operate the control switch downward <From 1994 models>.
4. Check to be sure that the speed is the desired constant speed when the switch is released, and also check to be sure that the CRUISE indicator light (within the combination meter) illuminates.

**NOTE**

If the vehicle speed decreases to approximately 15 km/h (9 mph) below the set speed, because of climbing a hill for example, the cruise control will be cancelled.

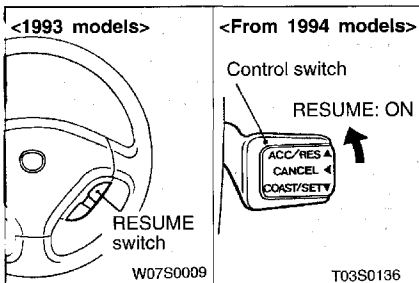

**SPEED-INCREASE SETTING CHECK**

110003807

1. Set to the desired speed.
2. Press the RESUME switch <1993 models> or operate the control switch upward <From 1994 models>.
3. Check to be sure that acceleration continues while the switch is hold, and that when it is released the constant speed at the time when it was released becomes the driving speed.

**SPEED REDUCTION SETTING CHECK**

110003808

1. Set to the desired speed.
2. Press the SET switch <1993 models> or operate the control switch downward <From 1994 models>.
3. Check to be sure that deceleration continues while the switch is held, and that when it is released the constant speed at the time when it was released becomes the driving speed.

**NOTE**

When the vehicle speed reaches the low limit [approximately 40 km/h (25 mph)] during deceleration, the cruise control will be cancelled.

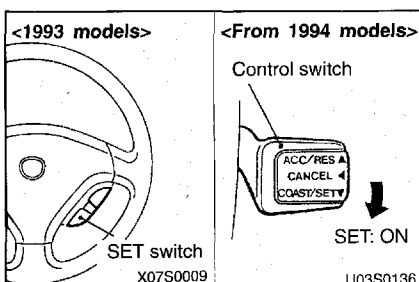

**AUTO-CRUISE CONTROL CANCELLATION AND SET SPEED RESUME CHECK**

110003809

1. Set auto-cruise control.
2. In the cruising condition of the cruise control mode, check that when any of the following operations are performed, the normal drive mode is restored and the vehicle coasts smoothly.
  - (1) Press the CANCEL switch <1993 models> or move the control switch toward you <From 1994 models>.
  - (2) Depress the brake pedal.
  - (3) Depress the clutch pedal. <M/T>
  - (4) Place the gear selector lever in the N range. <A/T>

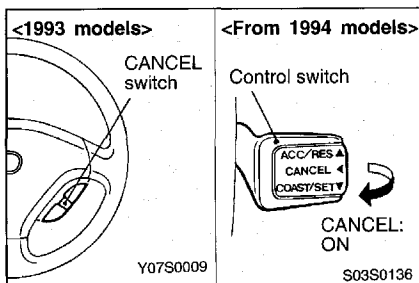

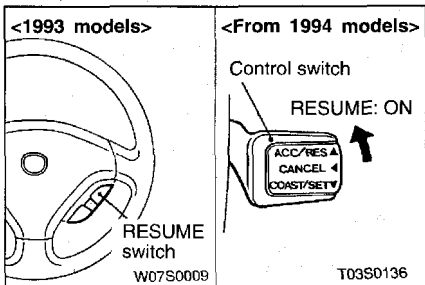

- With the vehicle at a speed of more than about 40 km/h (25 mph), check that when the RESUME switch is pressed <1993 models> or operate the control switch upward <From 1994 models>, the vehicle resumes cruising at the speed held before cancellation of the cruise control mode.
- In the cruise control mode, check that when the main switch is set to OFF, the normal drive mode is restored and the vehicle coasts smoothly.

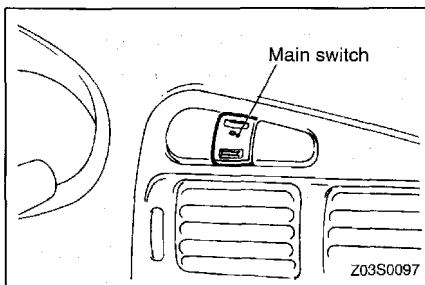

## INDIVIDUAL PARTS INSPECTION AUTO-CRUISE CONTROL MAIN SWITCH INSPECTION

110003810

- Remove the main switch. (Refer to P.13G-29.)

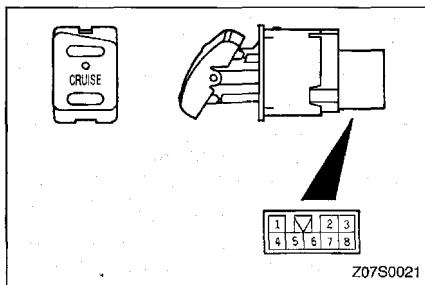

- Operate the main switch and check for continuity across the individual terminals.

Switch state	Terminal No.					
	2	ILL	7	1	4	5
Press OFF.	○	⊕	○			
Neutral position	○	⊕	○		○	○
Press ON.	○	⊕	○	○	○	○

### NOTE

ILL: Illumination light

- Connect a positive lead from the battery to terminal 1 and a negative lead from the battery to terminal 4 and check that battery voltage is available across terminal 5 and the ground during the period the ON side of the main switch is pressed and during the period before the OFF side is pressed thereafter.

Check that when the OFF side of the main switch is pressed thereafter, the battery voltage available across terminal 5 and the ground is reduced to 0 V.

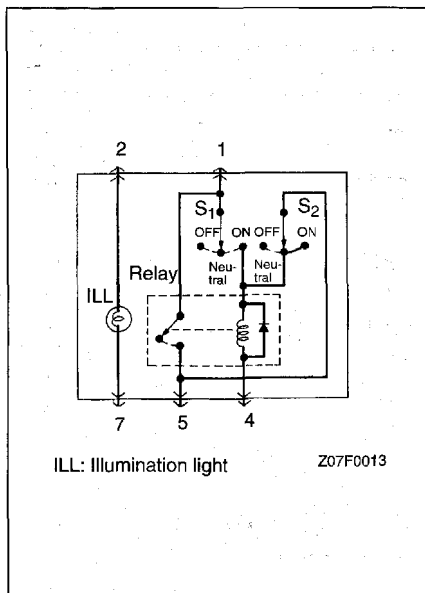

ILL: Illumination light

Z07F0013

<1993 models>      <From 1994 models>

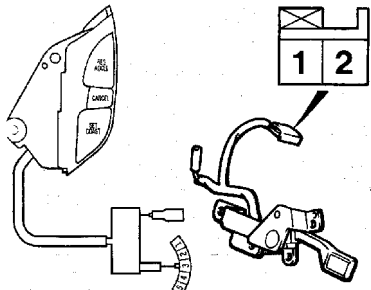

<1993 models> Z07S0022      Z03S0134

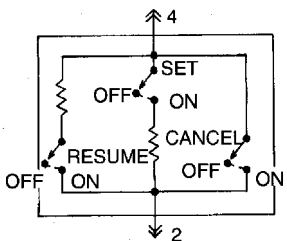

Z07N0014

<From 1994 models>

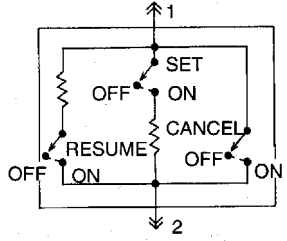

Z07N0014

**AUTO-CRUISE CONTROL SWITCH INSPECTION**

110003811

Disconnect the connector of the control switch and operate the control switch to measure the resistance between the individual terminals.  
If the readings are as shown below, the control switch may be considered good.

Switch operation	Resistance between terminals
When switch is not operated	No continuity
CANCEL switch: ON	Approx. 0 Ω
RESUME switch: ON	Approx. 820 Ω
SET switch: ON	Approx. 2,700 Ω

**CLOCK SPRING INSPECTION <From 1994 models>**

110003812

For inspection, refer to GROUP 52B – Air Bag Module and Clock Spring.

**STOP LIGHT SWITCH / BRAKE SWITCH INSPECTION**

110003994

1. Disconnect the connector.
2. Check for continuity between the terminals of the switch.

Measurement conditions	Brake switch terminal No.		Stop light switch terminal No.	
	1	4	2	3
When brake pedal depressed.			○ — ○	
When brake pedal not depressed.	○ — ○			

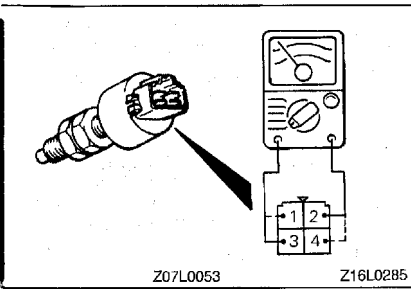

Z07L0053      Z16L0285

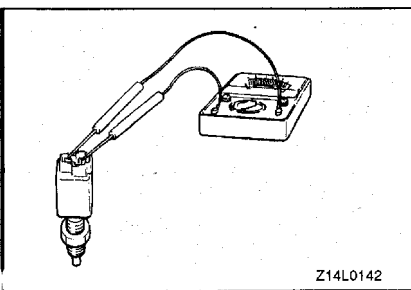

Z14L0142

**CLUTCH SWITCH INSPECTION <M/T>**

110003995

1. Disconnect the connector.
2. Check that there is continuity between the terminals when the clutch pedal is depressed, and that there is no continuity when the pedal is released.

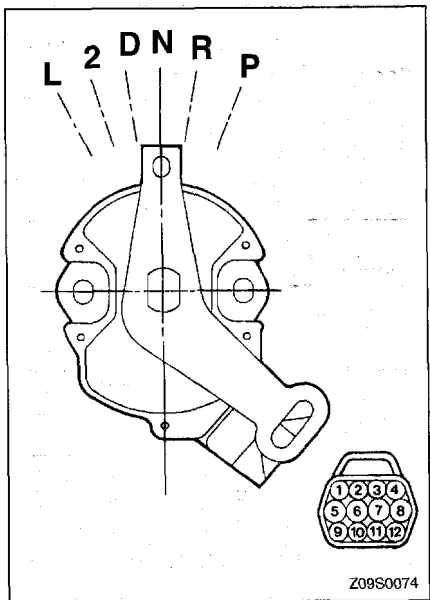

**PARK/NEUTRAL POSITION SWITCH (“N” POSITION) INSPECTION <A/T>**

110003996

1. Disconnect the connector.
2. Check to be sure that there is continuity between connector terminals 5 and 8 when the shift lever is moved to the “N” range.

**THROTTLE POSITION SENSOR INSPECTION**

110003877

For inspection, refer to GROUP 13A – On-vehicle Inspection of MFI Components.

**CLOSED THROTTLE POSITION SWITCH INSPECTION**

110003878

For inspection, refer to GROUP 13A – On-vehicle Inspection of MFI Components.

**VEHICLE SPEED SENSOR INSPECTION**

110003879

For inspection, refer to GROUP 54 – Meters and Gauges.

**VACUUM PUMP INSPECTION**

110003711

**Solenoid Valves Inspection (Control and Release Valves)**

1. Disconnect the connector of the vacuum pump assembly.
2. Measure the resistance values across terminals 1 and 2 and across terminals 1 and 3.

**Standard value: 50–60 Ω**

3. Check that when the battery voltage is applied across terminals 1 and 2 and across terminals 1 and 3, the operating sounds of the solenoid valves are heard.
4. If the solenoid valves are defective, replace the vacuum pump assembly.

**Motor Inspection**

1. Disconnect the connector of the vacuum pump assembly.
2. Check that when the battery voltage is applied across terminals 1 and 4, the motor operates.

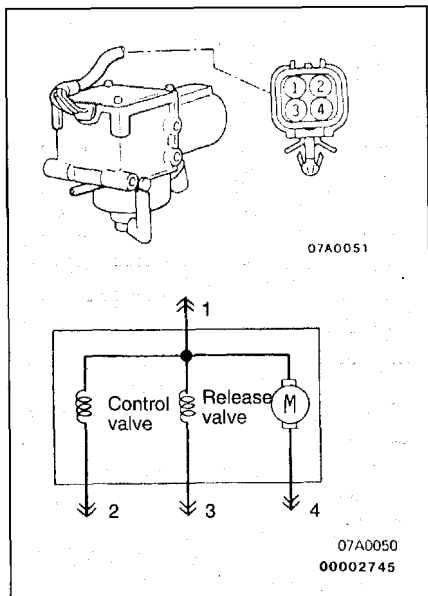

# AUTO-CRUISE CONTROL SYSTEM – Service Adjustment Procedures **13G-27**

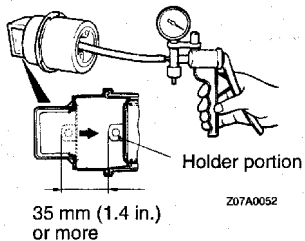

## ACTUATOR INSPECTION

110003816

1. Remove the actuator.
2. Using a vacuum pump, apply a negative pressure to the actuator to check that the holder portion moves more than 35 mm (1.4 in.). Retain the negative pressure in that state to check that the holder portion does not change its position.
3. After the actuator has been mounted, check and adjust the cruise control cable. (Refer to P.13G-21.)

## AUTO-CRUISE CONTROL SYSTEM

### REMOVAL AND INSTALLATION

#### Post-installation Operation

- Control Cable Inspection and Adjustment  
(Refer to P.13G-21.)

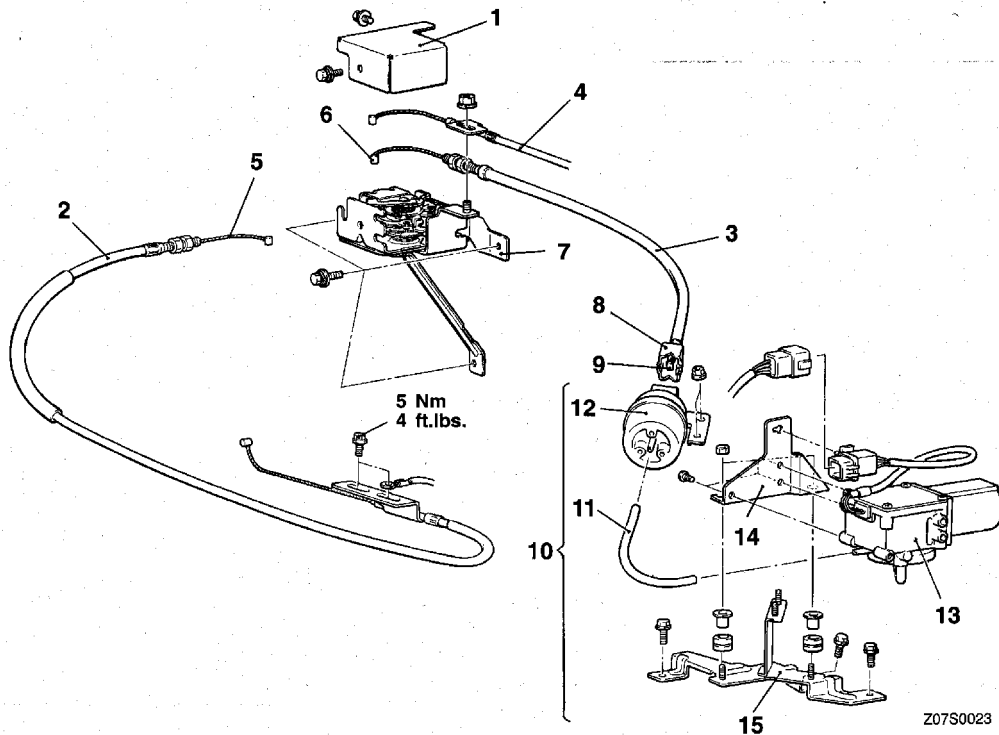

#### Throttle cable and auto-cruise control cable removal steps

1. Link protector
2. Throttle cable
3. Auto-cruise control cable

#### Link assembly removal steps

1. Link protector
4. Accelerator cable connection
5. Throttle cable connection
6. Auto-cruise control cable connection
7. Link assembly

#### Actuator removal steps

8. Cover
9. Auto-cruise control cable connection
10. Actuator and pump assembly  
(Part No. 11-15)
11. Vacuum hose
12. Actuator
13. Vacuum pump
14. Pump bracket
15. Actuator and pump bracket

Z07S0023

**CAUTION: SRS**  
 Before removal of air bag module, refer to GROUP 52B – SRS Service Precautions and Air Bag Module and Clock Spring.

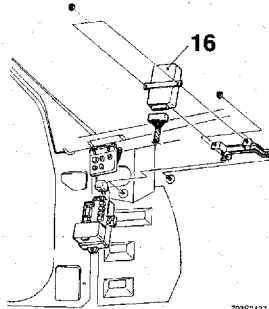

20352107

<1993 models>

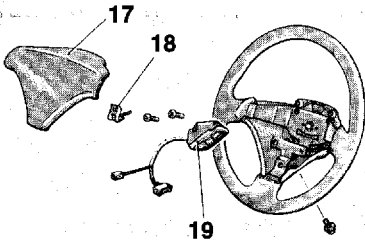

0350060

<From 1994 models>

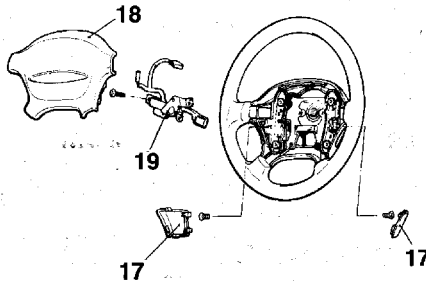

Z0750049

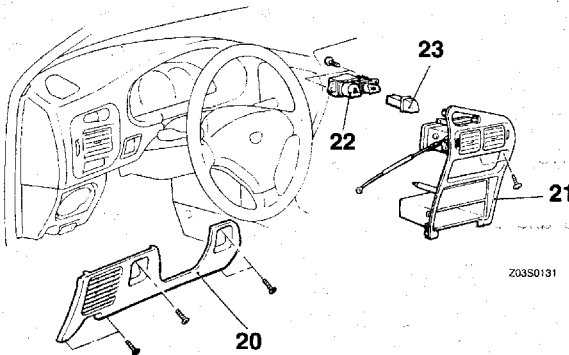

Z0380131

00001088

**Auto-cruise control unit removal**

- 16. Auto-cruise control unit

**Auto-cruise control switch removal steps <1993 models>**

- 17. Horn pad (Refer to GROUP 37A – Steering Wheel and Shaft.)
- 18. Spring holder (Refer to GROUP 37A – Steering Wheel and Shaft.)
- 19. Auto-cruise control switch

**<From 1994 models>**

- 17. Cover
- 18. Air bag module (Refer to GROUP 52B – Air Bag Module and Clock Spring.)
- 19. Auto-cruise control switch

**Auto-cruise control main switch removal steps**

- 20. Knee protector
- 21. Air outlet center panel assembly (Refer to GROUP 52A – Instrument Panel.)
- 22. Switch holder
- 23. Auto-cruise control main switch

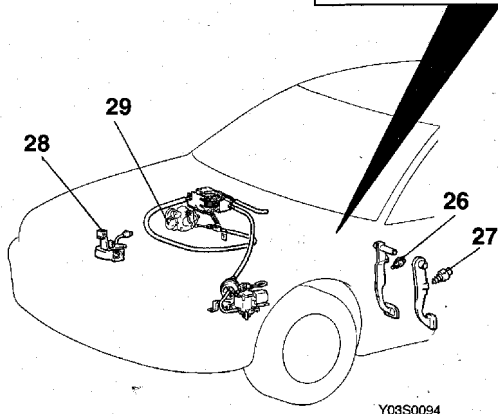
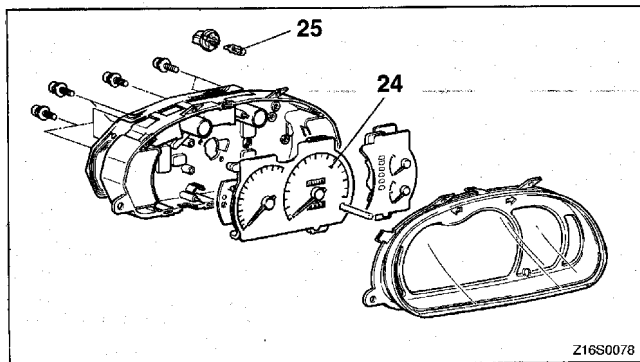

## Sensors removal steps

- 24. Vehicle speed sensor (Refer to GROUP 54 – Meters and Gauges.)
- 25. Auto-cruise control indicator light bulb (Refer to GROUP 54 – Meters and Gauges.)
- 26. Stop light switch (Refer to GROUP 54 – Meters and Gauges.)
- 27. Clutch switch <M/T>
- 28. Park/Neutral position switch <A/T>
- 29. Throttle position sensor (with built-in closed throttle position switch)

## INSPECTION

- Check the inner and outer cable for damage.
- Check the cable for smooth movement.
- Check the link protector for damage.