

FRONT SUSPENSION

CONTENTS

110003123

GENERAL INFORMATION	2	SPECIAL TOOLS	3
LOWER ARM	11	STABILIZER BAR	14
SERVICE ADJUSTMENT PROCEDURES	5	STRUT ASSEMBLY	6
Front Wheel Alignment Inspection and Adjustment	5	TROUBLESHOOTING	4
SERVICE SPECIFICATIONS	3		

GENERAL INFORMATION

110003124

The front suspension is a McPherson strut with coil spring. The shock absorber is hydraulic (vehicles produced in May, 1993 and after) or gas filled

hydraulic (vehicles produced up to April, 1993) double-acting type.

Coil spring

<1993 models>

Items	2-door models	4-door models	4-door models
		CB2ASNDEL CB2ASKDEL CB5ASNDEL CB5ASRJEL	CB2ASNDEL CB2ASKDEL CB5ASRDEL CB5ASRJEL
Wire dia. × O.D. × free length mm (in.)	12.0 × 145.0 × 324.1*1 (.47 × 5.71 × 12.76) 12.2 × 148.2 × 331.1*2 (.48 × 5.83 × 13.04)	12.2 × 148.2 × 331.1 (.48 × 5.83 × 13.04)	12.6 × 145.6 × 342.0 (.50 × 5.73 × 13.46)
Identification color	Pink + Purple*1 Pink + Brown*2	Pink + Brown	Pink + Gray
Spring constant N/mm (lbs./in.)	22.0 (123)	22.0 (123)	21.4 (120)

NOTE

*1: M/T

*2: A/T

<From 1994 models>

Items	CA2ADNSEL, CA2ADNMEL CA2ADNDEL	CA2ADKMEL, CA2ADKDEL CA5ADNDEL, CB2ASNDEL CB2ASKMEL, CB5ASNDEL CB2ASKDEL*2	CA5ADRDEL CB2ASKDEL*1 CB5ASRDEL CB5ASRJEL
Wire dia. × O.D. × free length mm (in.)	12.0 × 145.0 × 324.1 (.47 × 5.71 × 12.76)	12.2 × 148.2 × 331.1 (.48 × 5.83 × 13.04)	12.6 × 145.6 × 342.0 (.50 × 5.73 × 13.46)
Identification color	Pink + Purple	Pink + Brown	Pink + Gray
Spring constant N/mm (lbs./in.)	22.0 (123)	22.0 (123)	21.4 (120)

NOTE

*1: 1994 models

*2: From 1995 models

Shock absorber

Items	Specifications
Stroke mm (in.)	161 (6.3)
Damping force [at 0.3 m/sec. (.9 ft./sec.)]	Expansion N (lbs.)
	Contraction N (lbs.)
	950 (209)
	400 (88)

CONSTRUCTION DIAGRAM

110003125

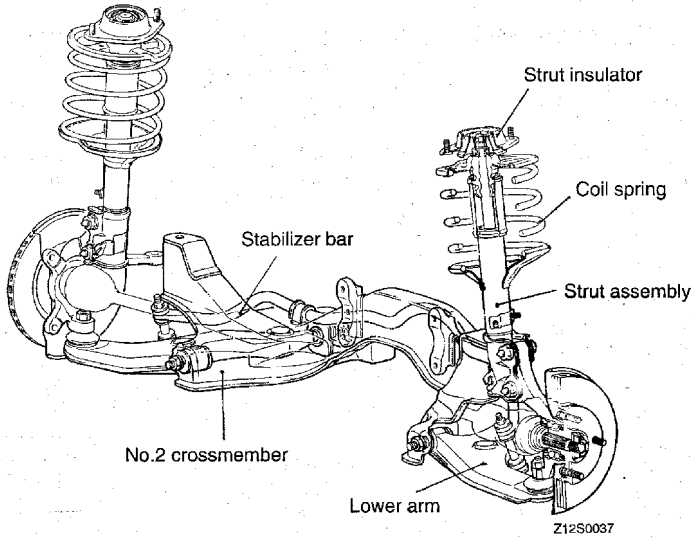

SERVICE SPECIFICATIONS



110003126

Items	Standard value
Toe-in mm (in.)	0 ± 3 (0 ± .12)
Camber	0°00' ± 30'
Caster	2°15'
Lower arm ball joint breakaway torque Nm (in.lbs.)	1.0-6.5 (9-56)
Protruding length of stabilizer bar mounting bolt mm (in.)	22 (.87)

SPECIAL TOOLS

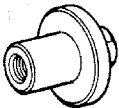
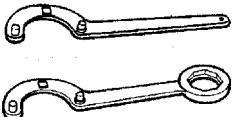
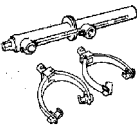
110003127

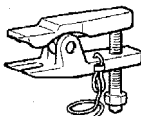
Tool	Tool number and name	Supersession	Application
	MB991004 Wheel alignment gauge attachment	MB991004-01 or General service tool	Measurement of the wheel alignment
	MB990278 or MB990775 Special spanner	MB990775-01	Disassembly/assembly of the strut assembly
	MB991237 Spring compressor body MB991238 Arm set	MIT62220	Compression of the front coil spring

Tool	Tool number and name	Supersession	Application
	MB991109 Deep socket	MB991109	Disassembly / assembly of the strut assembly
	MB991113 Steering linkage puller	MB991113-01	Removal of the lower arm ball joint
	MB990326 Preload socket	General service tool	Measurement of the lower arm ball joint rotation breakaway torque
	MB990800 Ball joint remover and installer	MB990800-01	Installation of the dust cover

TROUBLESHOOTING

110003128

Symptom	Probable cause	Remedy
Steering wheel is heavy, vibrates or pulls to one side	Suspension malfunction Ball joint Coil spring Wheel alignment	Adjust or replace
	Unbalanced or worn tires	
Excessive vehicle rolling	Broken or deteriorated stabilizer	Replace
	Shock absorber malfunction	
Poor riding	Improper tire inflation pressure	Adjust
	Broken or deteriorated coil spring	Replace
	Shock absorber malfunction	
Inclination of vehicle	Broken or deteriorated coil spring	Replace
Noise	Lack of lubrication	Lubricate
	Looseness and wear of each part	Replace
	Broken coil spring	
	Shock absorber malfunction	

SERVICE ADJUSTMENT PROCEDURES

110003129

FRONT WHEEL ALIGNMENT INSPECTION AND ADJUSTMENT

Measure wheel alignment with alignment equipment on a level surface.

The front suspension, steering system, and wheels should be serviced to normal condition prior to wheel alignment.

TOE-IN

Standard value: 0 ± 3 mm ($0 \pm .12$ in.)

If the toe-in is not within the standard value, adjust the toe-in by undoing the clips and turning the left and right tie rod turnbuckles by the same amount (in opposite directions).

NOTE

The toe will move out as the left turnbuckle is turned toward the front of the vehicle and the right turnbuckle is turned toward the rear of the vehicle.

For each half turn of the left and right tie rods, the toe-in will be adjusted by approx. 6 mm (.24 in.).

Caution

The difference between the left and right tie rods shall not exceed 5 mm (.21 in.).

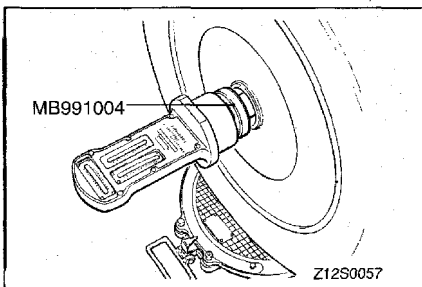
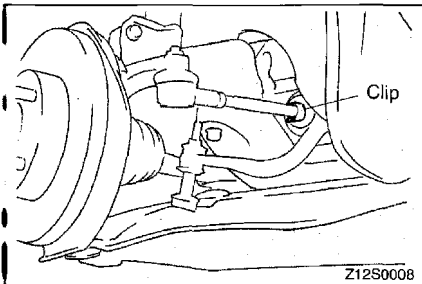

CAMBER AND CASTER

Standard value:

Camber $0^{\circ}00' \pm 30'$

Caster $2^{\circ}15'$

NOTE

1. Camber and caster are preset at the factory and cannot be adjusted.
2. If camber is not within the standard value, check and replace bent or damaged parts.
3. For vehicles with aluminum type wheels, attach the camber/caster/kingpin gauge to the drive shaft by using the special tool. Tighten the special tool to the same torque [200–260 Nm (145–188 ft.lbs.)) as the drive shaft nut.

Caution

Never subject the wheel bearings to the vehicle load when the drive shaft nuts are loosened.

STRUT ASSEMBLY

REMOVAL AND INSTALLATION

Post-installation Operation

- Front Wheel Alignment Adjustment
(Refer to P. 33A-5.)

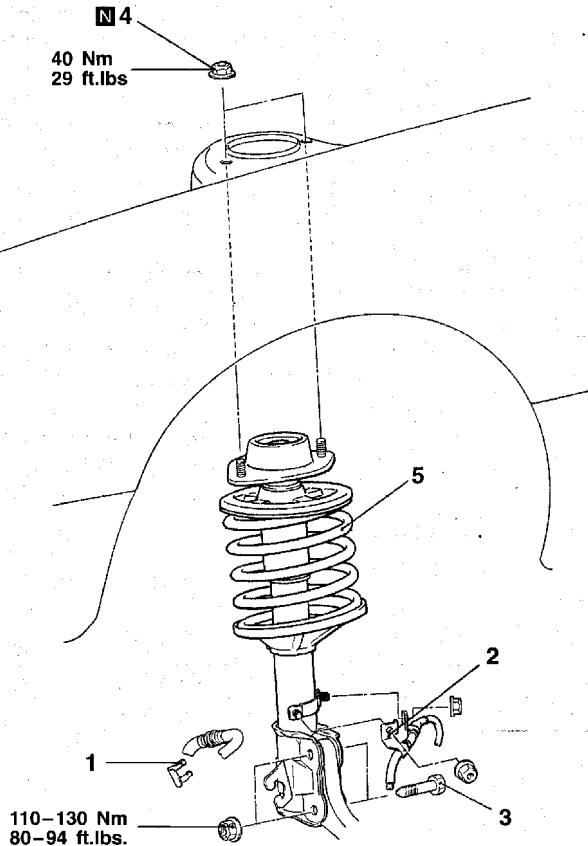

Z12S0014

Removal steps

1. Brake hose clamp
2. Front speed sensor bracket
<Vehicles with ABS>



3. Bolts
4. Flange nut
5. Strut assembly

REMOVAL SERVICE POINT**◀A▶ BOLTS REMOVAL**

- (1) Suspend the lower arm from the vehicle with wire
- (2) Remove the strut and knuckle connection.

INSPECTION

- Check for oil leaks from the strut assembly.
- Check the strut assembly for damage or deformation.

110003131

DISASSEMBLY AND REASSEMBLY
<1.5L Engine (Up to Jan. 1995) and 1.8L Engine>

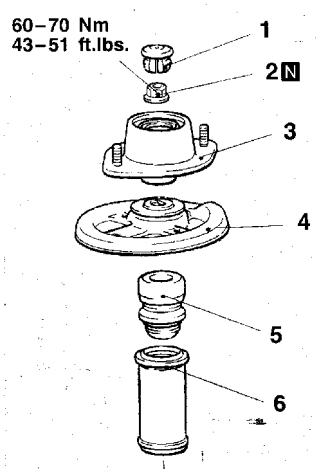
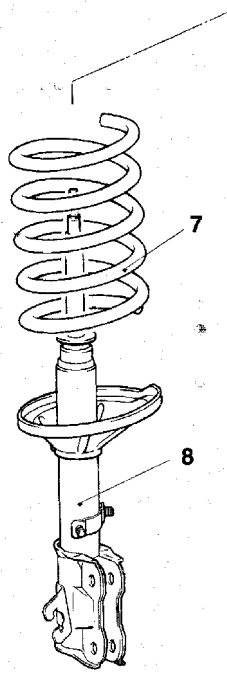
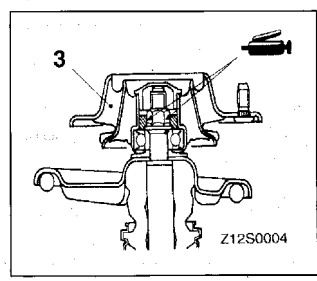

00001111

Disassembly steps

1. Dust cover
2. Flange nut
3. Strut insulator
4. Spring upper seat

5. Bump rubber
6. Dust cover
7. Coil spring
8. Strut assembly



DISASSEMBLY SERVICE POINTS

◀A▶ FLANGE NUT REMOVAL

- (1) Using the special tools, compress the coil spring.

NOTE

Install the special tools evenly, and so that the maximum length will be attained within the installation range.

Caution

Do not use an impact wrench to tighten the special tool bolt.

- (2) Holding the spring upper seat with the special tool, loosen the flange nut.

Caution

Do not use an impact wrench.

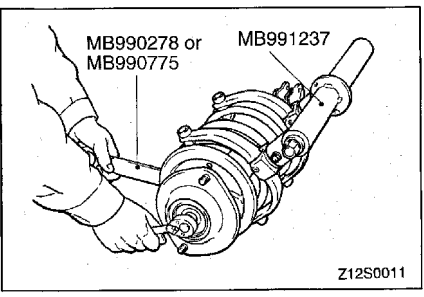
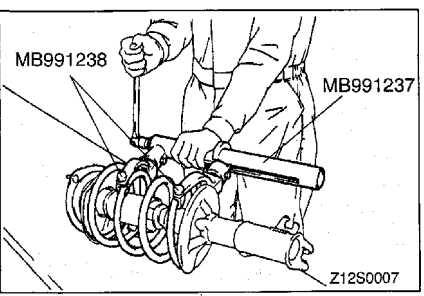

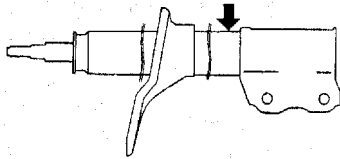

Z12P0310

◀B▶ STRUT ASSEMBLY REMOVAL <Up to Jun. 1994 models>

To discard the low pressure gas-filled strut assembly, place the assembly horizontally with its piston rod extended. Then drill a hole approx. 3 mm (.1 in.) in diameter at the location shown in the illustration and discharge the gas.

Caution

The gas itself is harmless but it may issue out of the hole together with chips generated by the drill. Therefore, be sure to wear goggles.

INSPECTION

- Check the strut insulator bearing for wear or rust.
- Check the rubber parts for damage or deterioration.
- Check the spring for deformation, deterioration or damage.
- Check the shock absorber for deformation.

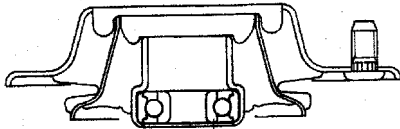

Strut insulator bearing

Z12S0058

REASSEMBLY SERVICE POINT

▶A◀ FLANGE NUT INSTALLATION

- (1) With the coil spring held compressed by the special tools (MB991237 and MB991238), provisionally tighten the flange nut.

Caution

Do not use an impact wrench to tighten the special tool bolt.

- (2) Line up the holes in the strut assembly spring lower seat with the hole in the spring upper seat.

NOTE

The job is easily accomplished with a pipe.

- (3) Correctly align both ends of the coil spring with the grooves in the spring seat, and then loosen the special tools (MB991237 and MB991238).
- (4) Using the special tool, tighten the flange nut to the specified torque.

Caution

Do not use an impact wrench.

- (5) Apply multipurpose grease to the bearing part of the strut insulator.

Caution

When applying the grease, take care that grease does not adhere to the insulator's rubber part.

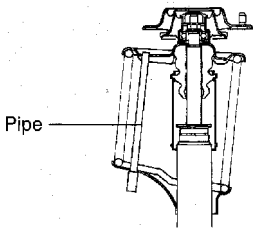

Pipe

Z12S0005

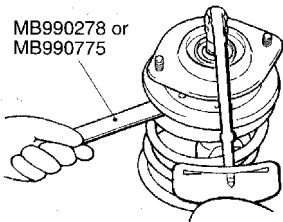
MB990278 or
MB990775

Z12S0010

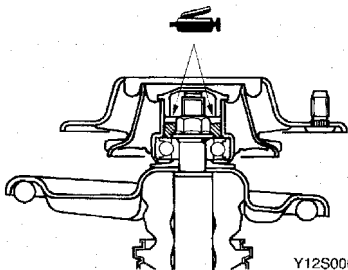

Y12S0004

DISASSEMBLY AND REASSEMBLY
<1.5L Engine (From Feb. 1995)>

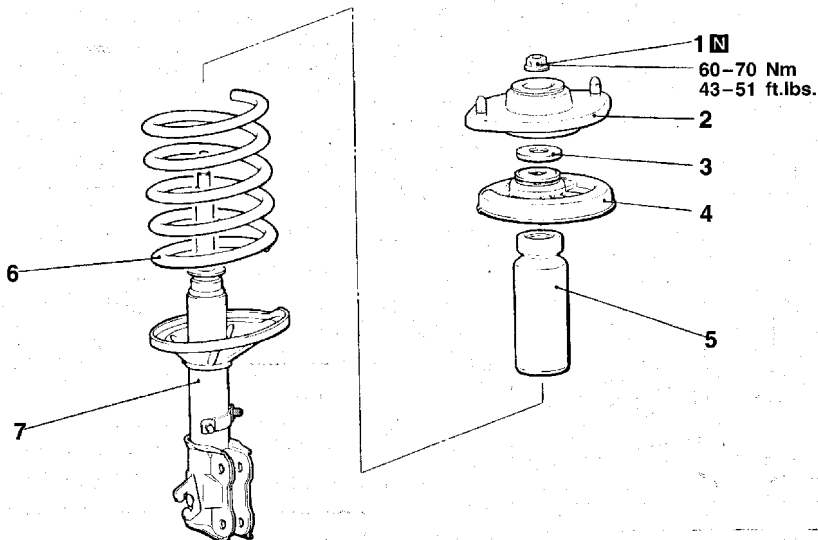

A12S0109

Disassembly steps

1. Flange nut
 2. Strut insulator
 3. Washer

4. Spring upper seat
 5. Bump rubber
 6. Coil spring
 7. Strut assembly

DISASSEMBLY SERVICE POINT

◀▶ FLANGE NUT REMOVAL

- (1) Using the special tools, compress the coil spring.

NOTE

Install the special tools evenly, and so that the maximum length will be attained within the installation range.

Caution

Do not use an impact wrench to tighten the special tool bolt.

- (2) Using the special tool, remove the flange nut.

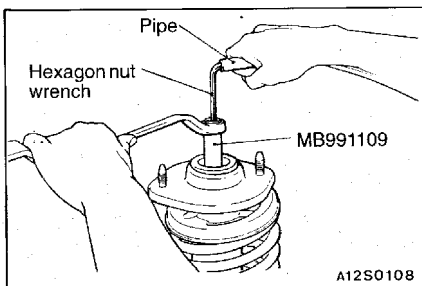
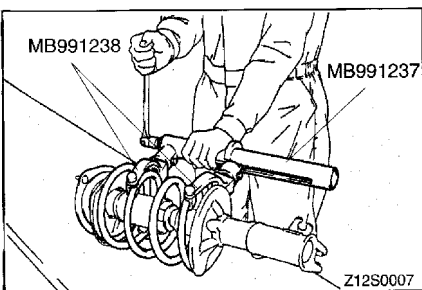

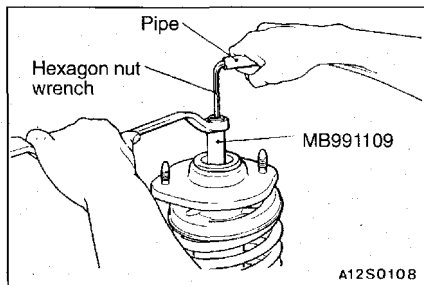
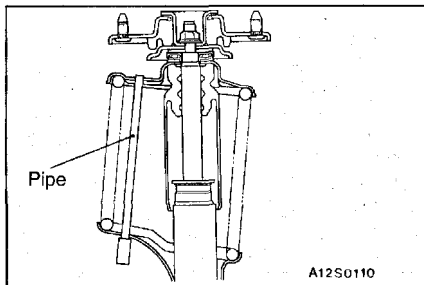
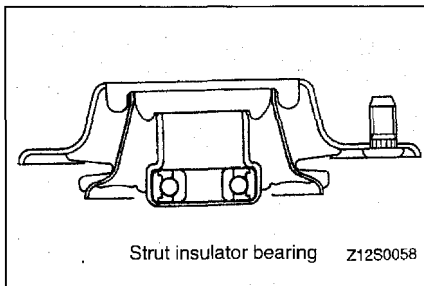

INSPECTION

- Check the strut insulator bearing for wear or rust.
- Check the rubber parts for damage or deterioration.
- Check the spring for deformation, deterioration or damage.
- Check the shock absorber for deformation.

REASSEMBLY SERVICE POINT

▶ A ◀ FLANGE NUT INSTALLATION

- (1) With the coil spring held compressed by the special tools (MB991237 and MB991238), provisionally tighten the flange nut.

Caution

Do not use an impact wrench to tighten the special tool bolt.

- (2) Line up the holes in the strut assembly spring lower seat with the hole in the spring upper seat.

NOTE

The job is easily accomplished with a pipe.

- (3) Correctly align both ends of the coil spring with the grooves in the spring seat, and then loosen the special tools (MB991237 and MB991238).
- (4) Using the special tool, tighten the flange nut to the specified torque.

LOWER ARM

REMOVAL AND INSTALLATION

Post-installation Operation
 • Front Wheel Alignment Adjustment
 (Refer to P. 33A-5.)

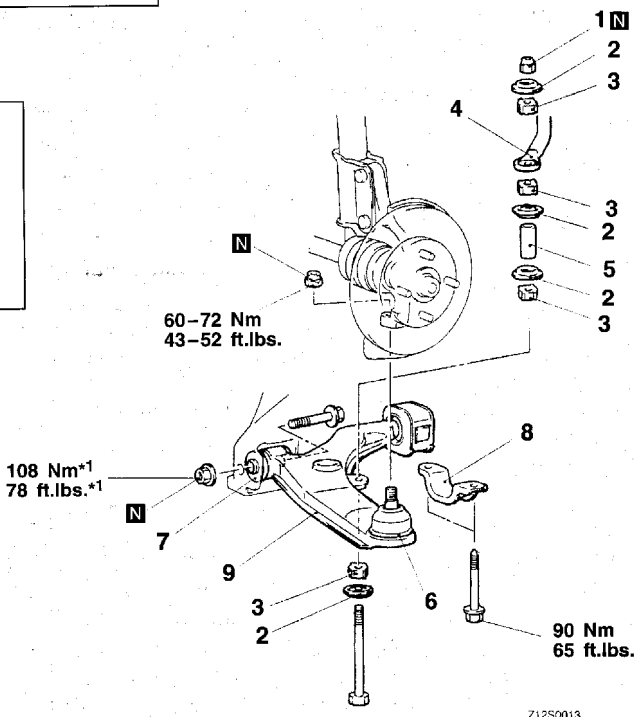
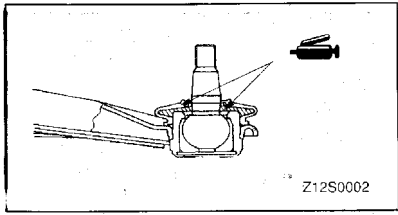

Z12S0013

00001112

Removal steps

- ▶▶A 1. Self-locking nut*2
- 2. Joint cup*2
- 3. Stabilizer rubber*2
- 4. Stabilizer bar*2
- 5. Collar*2
- ◀A 6. Lower arm ball joint connection
- 7. Lower arm front bushing connection
- 8. Support bracket
- 9. Lower arm

NOTE

*1: Indicates parts which should be temporarily tightened, and then fully tightened with the vehicle on the ground in the unladen condition.
 *2: <Vehicles with stabilizer bar>

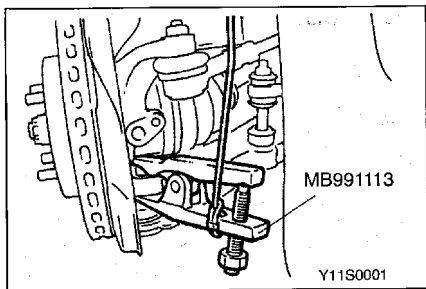

Y11S0001

REMOVAL SERVICE POINT

◀A> LOWER ARM BALL JOINT DISCONNECTION

Using the special tool, disconnect the lower arm ball joint from the knuckle.

Caution

- 1. Be sure to tie the cord of the special tool to a nearby part.
- 2. Loosen the nut but do not remove it.

INSPECTION

- Check the bushing for wear and deterioration.
- Check the lower arm for bend or breakage.
- Check the support bracket for deterioration or damage.
- Check the ball joint dust cover for cracks.
- Check all bolts for condition and straightness.

BALL JOINT BREAKAWAY TORQUE CHECK

- (1) After shaking the ball joint stud several times, install the nut to the stud and use the special tool to measure the rotation breakaway torque of the ball joint.

Standard value: 1.0–6.5 Nm (9–56 in.lbs.)

- (2) If the measured values exceed the standard values, replace the tie-rod end.
- (3) If the measured values are lower than the standard values, check that the ball joint does not feel stiff. If it doesn't feel stiff, it is possible to use the ball joint.

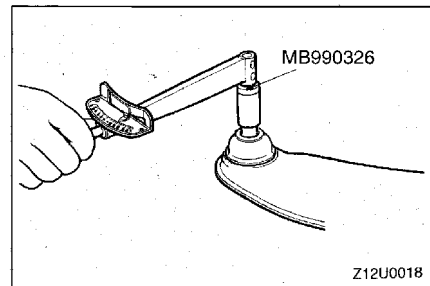

BALL JOINT DUST COVER REPLACEMENT

- (1) Remove the dust cover.
- (2) Apply multipurpose grease to the lip and inside of the dust cover.

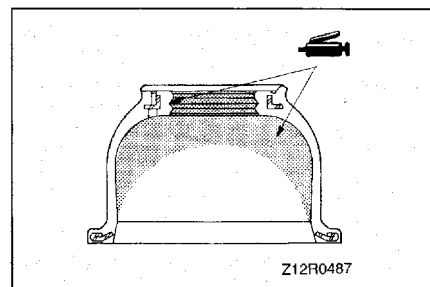

- (3) Drive in the dust cover with special tool until it is fully seated.

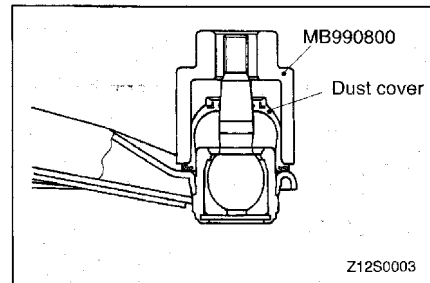

LOWER ARM REAR BUSHING REPLACEMENT

- (1) Apply soapy water between the shaft and old bushing, and pry up bushing using a screwdriver.
- (2) Apply soapy water to the shaft and new bushing and install new bushing into the shaft at the angle shown in the illustration.

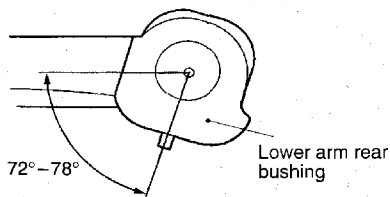

Z12C0035

- (3) Press in the bushing as illustrated.

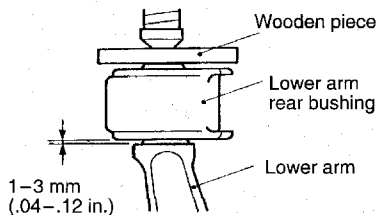

Z12C0037

INSTALLATION SERVICE POINT**▶ A ◀ SELF-LOCKING NUT INSTALLATION**

Tighten the self-locking nut so that the amount of protrusion of the end of the stabilizer bar mounting bolt is at the standard value.

Standard value (A): 22 mm (.87 in.)

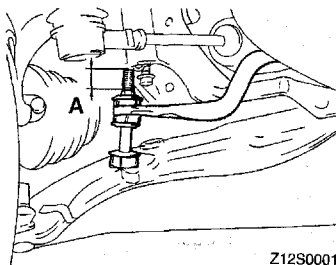

Z12S0001

STABILIZER BAR

REMOVAL AND INSTALLATION

Pre-removal and Post-installation Operation

- No. 2 Crossmember Installation Bolt Removal and Installation (Refer to GROUP 32 – No.2 Crossmember.)

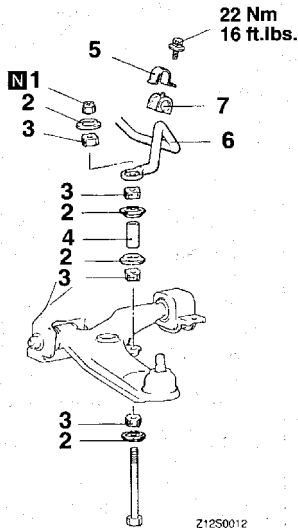

Removal steps

- A◄
1. Self-locking nut
 2. Joint cup
 3. Stabilizer rubber

4. Collar
5. Fixture
6. Stabilizer bar
7. Stabilizer bushing

INSPECTION

- Check the bushing for wear and deterioration.
- Check the stabilizer bar for deterioration or damage.

INSTALLATION SERVICE POINT

►A◄ SELF-LOCKING NUT INSTALLATION

Tighten the self-locking nut so that the amount of protrusion of the end of the stabilizer bar mounting bolt is at the standard value.

Standard value (A): 22 mm (.87 in.)

