

STEERING

CONTENTS

110003205

GENERAL INFORMATION	2	Fluid Level Check	10
LUBRICANTS	3	Fluid Replacement	11
MANUAL STEERING GEAR BOX*	20	Oil Pump Pressure Test	13
POWER STEERING GEAR BOX*	26	Power Steering Pressure Switch Check	14
POWER STEERING HOSES	45	Stationary Steering Effort Check	9
POWER STEERING OIL PUMP	36	Steering Angle Check	8
SEALANT AND ADHESIVES	4	Steering Wheel Free Play Check	8
SERVICE ADJUSTMENT PROCEDURES	8	Tie-rod End Ball Joint Breakaway Torque Check	9
Bleeding	12	SERVICE SPECIFICATIONS	3
Checking Steering Wheel Return to Center	10	SPECIAL TOOLS	4
Drive Belt Tension Check	10	STEERING WHEEL AND SHAFT*	15
		TROUBLESHOOTING	6

WARNINGS REGARDING SERVICING OF SUPPLEMENTAL RESTRAINT SYSTEM (SRS) EQUIPPED VEHICLES

WARNING!

- (1) Improper service or maintenance of any component of the SRS, or any SRS-related component, can lead to personal injury or death to service personnel (from inadvertent firing of the air bag) or to the driver and passenger (from rendering the SRS inoperative).
- (2) Service or maintenance of any SRS component or SRS-related component must be performed only at an authorized MITSUBISHI dealer.
- (3) MITSUBISHI dealer personnel must thoroughly review this manual, and especially its GROUP 52B – Supplemental Restraint System (SRS) and GROUP 00 – Maintenance Service, before beginning any service or maintenance of any component of the SRS or any SRS-related component.

NOTE

The SRS includes the following components: SRS air bag control unit, SRS warning light, air bag module, clock spring and interconnecting wiring. Other SRS-related components (that may have to be removed/installed in connection with SRS service or maintenance) are indicated in the table of contents by an asterisk (*).

GENERAL INFORMATION

- The steering wheel is available either with two spokes or three spokes. <1993 models> The steering wheel is of a four spoke type and has the SRS (supplemental restraint system) incorporated. <From 1994 models>
- The steering column is equipped with both a shock absorbing and a tilt steering mechanism.
- The manual steering gear is a rack and pinion type with constant gear ratio which features light-weight, compact size, good response to steering wheel movement and excellent feeling of steering.
- The power steering is an integral rack and pinion type that combines the steering gear and linkage into one light-weight and compact assembly.
- The steering system uses a vane oil pump with a fluid flow control system, so that steering effort varies with engine speed.

CONSTRUCTION DIAGRAM

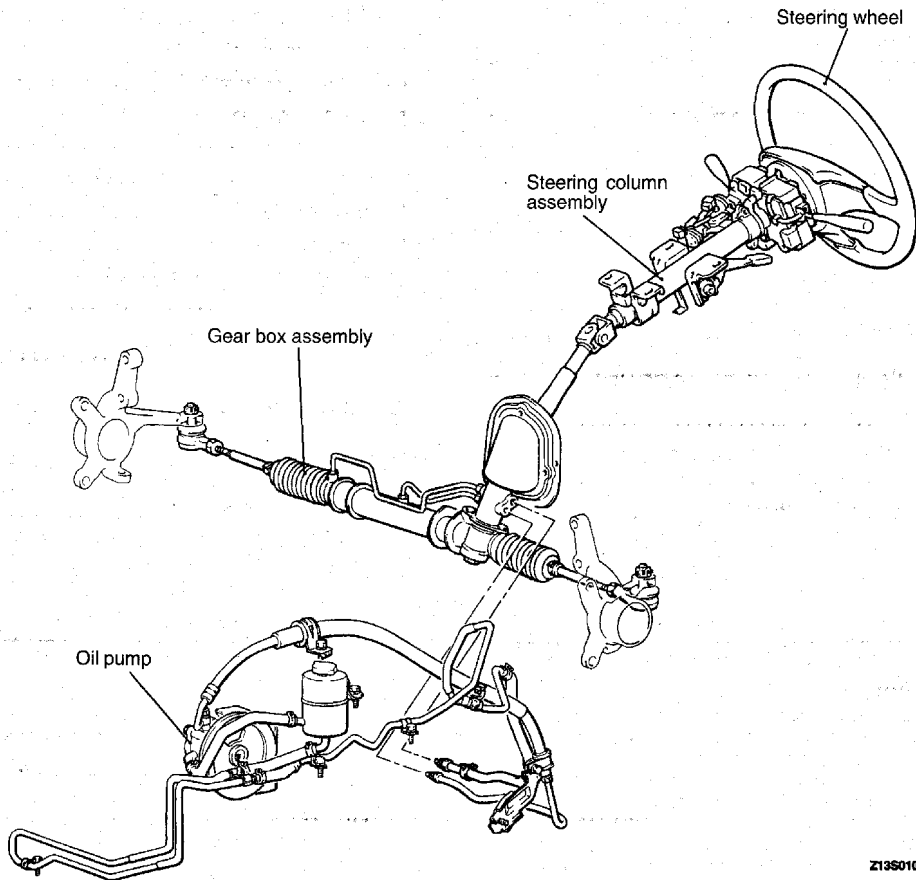

SERVICE SPECIFICATIONS

110003208

Items		Standard value	Limit
Steering wheel free play mm (in.)	Manual steering	–	30 (1.2)
	Power steering (with engine stopped)	10 (.39) or less	–
	Power steering (when hydraulic operation)	–	30 (1.2)
Steering angle	Inner wheel	37°18' ± 1°00'	–
	Outer wheel	31°00'	–
Tie rod end ball joint breakaway torque Nm (in.lbs.)		0.5–2.5 (4–22)	–
Stationary steering effort N (lbs.)		37 (26.7) or less [Fluctuation allowance 6 (1.3) or less]	–
Oil pump pressure MPa (psi)	Oil pump relief pressure	9.5–10.2 (1,351–1,451)	–
	Pressure under no-load conditions	0.8–1.0 (114–142)	–
	Steering gear retention hydraulic pressure	9.5–10.2 (1,351–1,451)	–
Oil pressure switch operating pressure MPa (psi)	OFF → ON	1.5–2.0 (213–284)	–
	ON → OFF	0.7–2.0 (100–284)	–
Oil pump pulley assembly backlash mm (in.)		–	0.1 (.004)
Total pinion preload Nm (in.lbs.)	Manual steering gear box	0.3–1.4 (3–12)	–
	Power steering gear box	0.6–1.4 (5–12)	–
Tie-rod joint swing torque Nm (in.lbs.)		2–5 (17–43)	–

LUBRICANTS

110003209

Items		Specified lubricant	Quantity
Manual steering gear box	Bellows	Silicone grease	As required
Power steering gear box	Bearing, O-ring and oil seal	Automatic transmission fluid “DEXRON II”	
	Bush inside rack stopper		
	Special tool (MB991212)		
	Pinion and valve assembly seal ring part		
	Bellows	Silicone grease	
Oil pump	Flow control valve	Automatic transmission fluid “DEXRON II”	
	Friction surface of rotor, vane, cam ring and pump cover		
	O-ring		
	Power steering fluid	0.9 dm ³ (0.95 qts.)	



SEALANT AND ADHESIVES





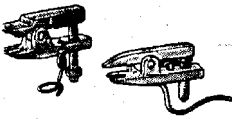

110003210

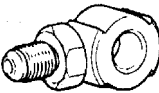
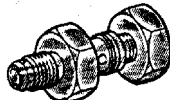
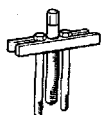
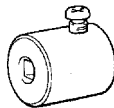
Items		Specified sealant and adhesive
Gear box	Rack support cover screw	3M ATD Part No. 8663 or equivalent
	Dust cover lip for tie rod end ball joint	
	End plug screw (power steering)	

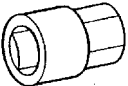
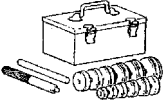
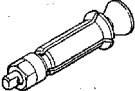
SPECIAL TOOLS

110003211

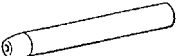
Tool	Tool number and name	Supersession	Application
	MB991113 or MB990635 Steering linkage puller	MB991113-01	Disconnection of tie-rod end
	MB990326 Preload socket	General service tool	Measurement of the ball joint <i>breakaway torque</i>
	MB990662 Oil pressure gauge as- sembly	MB990662-01	Measurement of oil pressure
	MB990993 or MB991217 Power steering oil pressure gauge adapter (pump side)	MB990993-01	
	MB990994 Power steering oil pressure gauge adapter (hose side)	MB990994-01	
	MB990803 Steering wheel puller	General service tool	Disconnection of the steering wheel
	MB991006 Preload socket	MB991006-01	Measurement of the pinion shaft preload

Tool	Tool number and name	Supersession	Application
	MB990607 Torque wrench socket	MB990607-01	Adjustment of rack support Removal of rack support cover
	MB990925 Bearing and oil seal installer set	MB990925-01 or General service tool	Installation of the oil seal and bearing
	MB991120 Needle bearing puller	Tool not available	Removal of rack housing needle bearing
	MB991197 Bar (long type)	General service tool	To press in the oil seal for the rack
	MB991452 Oil seal installer	General service tool	
	MB991202 Oil seal & bearing installer	General service tool	Press fitting of rack housing bearing
	MB991212 Rack installer	Tool not available	Rack installation
	MB991203 Oil seal & bearing installer	Tool not available	To press in the valve housing oil seal and bearing
	MB991317 Seal ring installer	Tool not available	Compression of the seal rings after replacement of the pinion seal rings

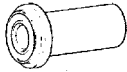
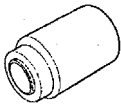
Tool	Tool number and name	Supersession	Application
	MB990941 Dust cover installer	MB990941-01	To press in the column tube lower part bearing
	MB990776 Front axle base	MB990776-01	Installation of dust cover for tie rod end ball joint

TROUBLESHOOTING

110003212

MANUAL STEERING

Symptom	Probable cause	Remedy
Excessive play of steering wheel	Loose rack support cover	Retighten
	Loose steering gear mounting bolts	
	Loose or worn stud of tie-rod end	Retighten or replace as necessary
Steering wheel operation is hard	Excessive turning resistance of tie-rod ball joint	Replace
	Excessively tightened rack support cover	Adjust
	Rough turning of inner tie-rod and/or ball joint	Lubricate or replace ball joint
	Bent rack	
	Worn steering shaft joint and/or body grommet	
	Damaged pinion bearing	
Steering wheel does not return properly	Excessive turning resistance of tie-rod ball joint	Replace
	Excessively tightened rack support cover	Adjust
	Rough turning of inner tie-rod and/or ball joint	Replace
	Worn steering shaft joint and/or body grommet	Correct or replace
	Bent rack	Replace
	Damaged pinion bearing	

POWER STEERING

110003213

Symptom	Probable cause	Remedy
Excessive play of steering wheel	Loose rack support cover	Retighten
	Loose steering gear mounting bolts	
	Loose or worn stud of tie-rod end	Retighten or replace as necessary

Symptom	Probable cause	Remedy
Steering wheel operation is hard (Improper power assist)	Drive belt slippage	Check
	Damaged drive belt	Replace
	Low fluid level	Refill
	Air in the fluid	Bleed
	Twisted or damaged hoses	Correct the routing or replace
	Improper oil pump pressure	Repair or replace oil pump
	Sticky flow control valve	Replace
	Excessive internal oil pump leakage	Replace damaged parts
	Excessive oil leaks from rack & pinion in gear box	
	Bent or damaged gear box or valve body seal ring	Replace
Steering wheel does not return properly	Excessive turning resistance of tie-rod ball joint	Replace
	Excessively tightened rack support cover	Adjust
	Rough turning of inner tie-rod and/or ball joint	Replace
	Worn steering shaft joint and/or body grommet	Correct or replace
	Bent rack	Replace
	Damaged pinion bearing	
	Twisted or damaged hoses	Reroute or replace
	Damaged flow control valve	Replace
Damaged oil pump input shaft bearing		
Noise	<p>Hissing Noise in Steering Gear There is some noise in all power steering systems. One of the most common is a hissing sound when the steering wheel is turned and the car is not moving. This noise will be most evident when turning the wheel while the brakes are applied. There is no relationship between this noise and steering performance. Do not replace the valve unless the "hissing" noise is extremely objectionable. A replacement valve will also have a slight noise, and is not always a cure for the condition.</p>	
Rattling or chucking noise in rack & pinion	Pressure hose touching other parts of vehicle	Reroute
	Loose gear box mounting bolts	Retighten
	Loose tie-rod end ball joint	
	Worn tie-rod end ball joint	Replace
Groaning noise in oil pump	Low fluid level	Refill
	Air in the fluid	Bleed
	Loose pump mounting bolts	Retighten

SERVICE ADJUSTMENT PROCEDURES

110003214

STEERING WHEEL FREE PLAY CHECK

<Manual steering>

1. Set front wheels straight ahead.
2. Measure the play on steering wheel circumference before wheels move when slightly moving steering wheel in both directions.

Limit: 30 mm (1.2 in.)

3. When the play exceeds the limit, check play in steering shaft connection and steering linkage. Correct or replace.
4. When (3) check provides good results, check the following to adjust:
 - Remove the steering gear box, check and adjust total pinion starting torque.

<Power steering>

1. With engine running (hydraulic operation), set front wheels straight ahead.
2. Measure the play on steering wheel circumference before wheels start to move when slightly moving steering wheel in both directions.

Limit: 30 mm (1.2 in.)

3. When play exceeds the limit, check for play on steering shaft connection and steering linkage. Correct or replace.
4. If the free play still exceeds the limit value, set steering wheel straight ahead with engine stopped. Load 5 N (1 lb.) towards steering wheel circumference and check play.

Standard value (steering wheel play with engine stopped): 10 mm (.39 in.) or less

If the play exceeds the standard value, remove steering gear box and check total pinion torque.

STEERING ANGLE CHECK

110003215

1. Locate front wheels on turning radius gauge and measure steering angle.

Standard value:

Inside wheel $37^{\circ}18' \pm 1^{\circ}00'$

Outside wheel $31^{\circ}00'$

2. When the angle is not within the standard value, the toe is probably incorrect. Adjust toe (Refer to GROUP 33A - Service Adjustment Procedures) and recheck steering angle.

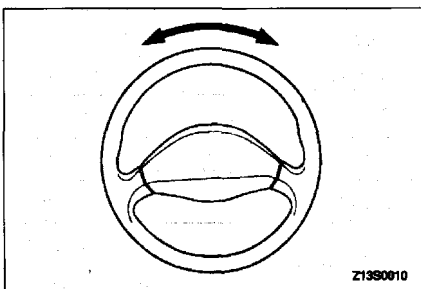

Z1390010

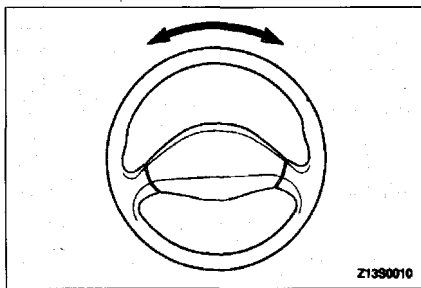

Z1390010

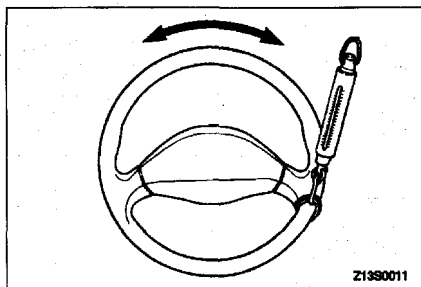

Z1390011

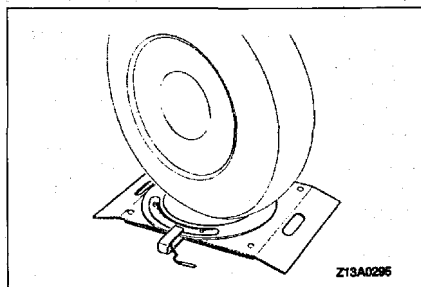

Z13A0295

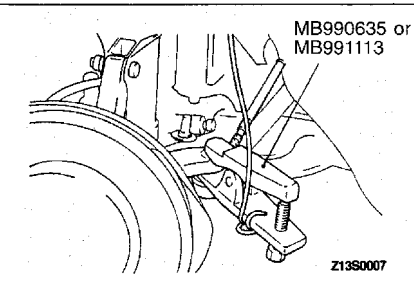

TIE-ROD END BALL JOINT BREAKAWAY TORQUE CHECK

110003216

1. Disconnect tie rod and knuckle with special tool.

Caution

1. Be sure to tie the cord of the special tool to a nearby part.
2. Loosen the nut but do not remove it.

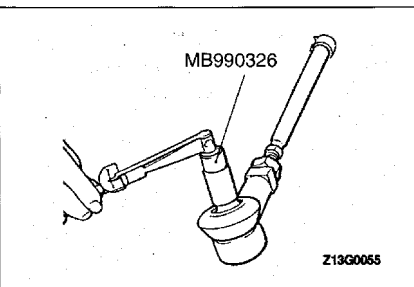

2. Move ball joint stud several times and install nut on stud. Measure ball joint breakaway torque with special tools.

Standard value: 0.5–2.5 Nm (4–22 in.lbs.)

3. When the breakaway torque exceeds the standard value, replace the rod end.
4. When the breakaway torque is under the standard value, check ball joint for end play or ratcheting. If none of these, the joint is still serviceable.

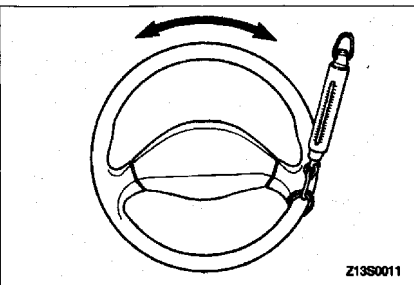

STATIONARY STEERING EFFORT CHECK

110003217

1. With the vehicle stopped on a flat, paved surface, turn the steering wheel to the straight ahead position.
2. Start the engine and set it to $1,000 \pm 100$ r/min.

Caution

After checking the engine rpm, there must be a return to the standard idling rpm.

3. Attach a spring balance to the outer circumference of the steering wheel and measure the steering force required to turn the steering wheel from the straight ahead position to the left and right (within a range of 1.5 turns). Also check to be sure that there is no significant fluctuation of the required steering force.

Standard value: 37 N (26.7 lbs.) or less

[Fluctuation allowance: 6 N (1.3 lbs.) or less]

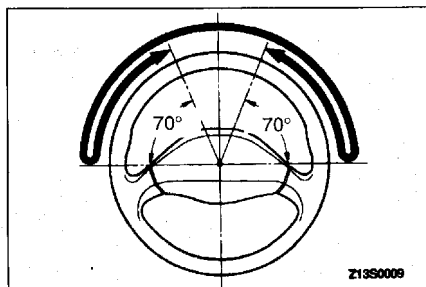

CHECKING STEERING WHEEL RETURN TO CENTER

110003218

To make this test, conduct a road test and check as follows.

1. Make both gradual and sudden turns and check the steering "feeling" to be sure that there is no difference in the steering force required and the wheel return between left and right turns.
2. At a speed of 35 km/h (22 mph), turn the steering wheel 90° , and release the steering wheel after 1 or 2 seconds. If the steering wheel then returns 70° or more, the return can be judged to be satisfactory.

NOTE

There will be a momentary feeling or "heaviness" when the wheel is turned quickly, but this is not abnormal. (This is because the oil pump discharge amount is especially apt to be insufficient during idling.)

DRIVE BELT TENSION CHECK

110003219

Refer to GROUP 11 – Service Adjustment Procedures.

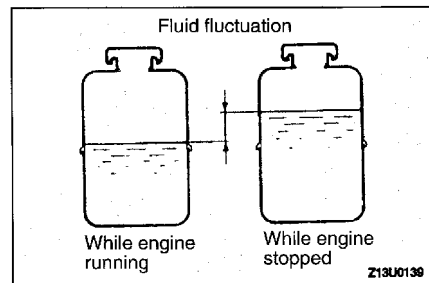

FLUID LEVEL CHECK

110003220

1. Park the vehicle on a flat, level surface, start the engine, and then turn the steering wheel several times to raise the temperature of the fluid to approximately $50\text{--}60^\circ\text{C}$ ($122\text{--}140^\circ\text{F}$).
2. With the engine running, turn the wheel all the way to the left and right several times.
3. Check the fluid in the oil reservoir for foaming or milkiness. Check the fluid fluctuation when the engine is stopped and while it is running. If the fluid level changes considerably, air bleeding should be done.

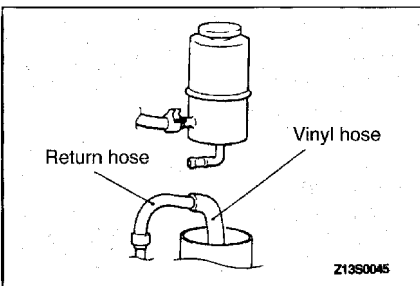

FLUID REPLACEMENT

110003221

1. Raise the front wheels on a jack, and then support them with rigid racks.
2. Disconnect the return hose connection.
3. Connect a vinyl hose to the return hose, and drain the oil into a container.
4. Disconnect the high-tension cable.
While operating the starting motor intermittently, turn the steering wheel all the way to the left and right several times to drain all of the fluid.

Caution

Be careful not to position the high-tension cable near the carburetor or the fuel rail.

5. Connect the return hoses securely, and then secure it with the clip.
6. Fill the oil reservoir with the specified fluid up to the lower position of the filter, and then bleed the air.

Specified fluid:

Automatic transmission fluid "DEXRON II"

BLEEDING

1. Jack up the front wheels and support them by using a rigid rack.
2. Manually turn the oil pump pulley a few times.
3. Turn the steering wheel all the way to the left and to the right five or six times.
4. Disconnect the high-tension cable. While operating the starting motor intermittently, turn the steering wheel all the way to the left and right five or six times (for 15 or 20 seconds).

Caution

1. **During air bleeding, replenish the fluid supply so that the level never falls below the lower position of the filter.**
2. **If air bleeding is done while engine is running, the air will be broken up and absorbed into the fluid; be sure to do the bleeding only while cranking.**
5. Connect the high-tension cable and start the engine (idling).
6. Turn the steering wheel to the left and right until there are no air bubbles in the oil reservoir.
7. Confirm that the fluid is not milky, and that the level is up to the specified position on the level gauge.
8. Confirm that there is very little fluid fluctuation when the steering wheel is turned left and right.
9. Check whether or not the fluid fluctuation is within 5 mm (.2 in.) when the engine is stopped and when it is running.
10. If the fluid fluctuation is 5 mm (.2 in.) or more, the air has not been completely bled from the system, and thus must be bled completely.

Caution

1. **If the fluid level rises suddenly after the engine is stopped, the air has not been completely bled.**
2. **If air bleeding is not complete, there will be abnormal noises from the pump and the flow-control valve, and this condition could cause a lessening of the life of the pump, etc.**

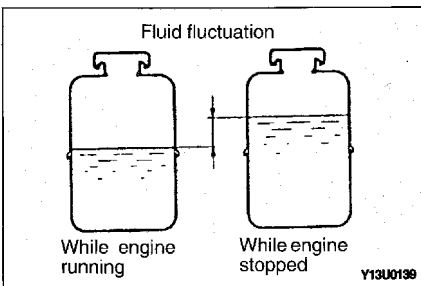

110003223

OIL PUMP PRESSURE TEST**CHECKING THE OIL PUMP RELIEF PRESSURE**

1. Disconnect the pressure hose from the oil pump, and then connect the special tools.
2. Bleed the air, and then turn the steering wheel several times while the vehicle is not moving so that the temperature of the fluid rises to approximately 50–60°C (122–140°F).
3. Start the engine and idle it at $1,000 \pm 100$ r/min.
4. Fully close the shut-off valve of the pressure gauge and measure the oil pump relief pressure to confirm that it is within the standard value range.

Standard value: 9.5–10.2 MPa (1,351–1,451 psi)

Caution

Pressure gauge shut off valve must not remain closed for more than 10 seconds.

5. If it is not within the standard value, overhaul the oil pump.
6. Remove the special tools, and then tighten the pressure hose to the specified torque.
7. Bleed the system.

CHECKING THE PRESSURE UNDER NO-LOAD CONDITIONS

1. Disconnect the pressure hose from the oil pump, and then connect the special tools.
2. Bleed the air, and then turn the steering wheel several times while the vehicle is not moving so that the temperature of the fluid rises to approximately 50–60°C (122–140°F).
3. Start the engine and idle it at $1,000 \pm 100$ r/min.
4. Check whether or not the hydraulic pressure is the standard value when no-load conditions are created by fully opening the shut-off valve of the pressure gauge.

Standard value: 0.8–1.0 MPa (114–142 psi)

5. If it is not within the standard value, the probable cause is a malfunction of the oil line or steering gear box, so check these parts and repair as necessary.
6. Remove the special tools, and then tighten the pressure hose to the specified torque.
7. Bleed the system.

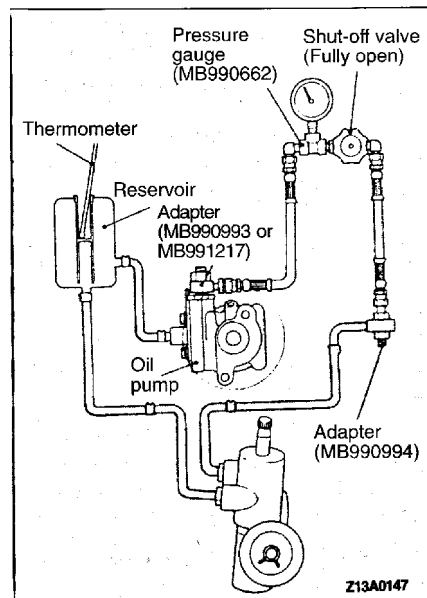
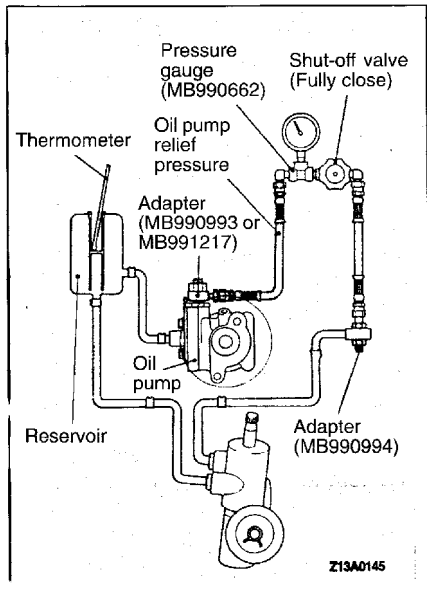

CHECKING THE STEERING GEAR RETENTION HYDRAULIC PRESSURE

1. Disconnect the pressure hose from the oil pump, and then connect the special tools.
2. Bleed the air, and then turn the steering wheel several times while the vehicle is not moving so that the temperature of the fluid rises to approximately 50–60°C (122–140°F).
3. Start the engine and idle it at $1,000 \pm 100$ r/min.
4. Fully open the shut-off valve of the pressure gauge.
5. Turn the steering wheel all the way to the left or right; then check whether or not the retention hydraulic pressure is the standard value.

Standard value: 9.5–10.2 MPa (1,351–1,451 psi)

6. When not within the standard value, overhaul the steering gear box. Remeasure fluid pressure.
7. Remove the special tools, and then tighten the pressure hose to the specified torque.
8. Bleed the system.

POWER STEERING PRESSURE SWITCH CHECK

110003224

1. Disconnect the pressure hose from the oil pump, and then connect the special tools.
2. Bleed the air, and then turn the steering wheel several times while the vehicle is not moving so that the temperature of the fluid rises to approximately 50–60°C (122–140°F).
3. The engine should be idling.
4. Disconnect the connection of the connector for the pressure switch, and place an ohmmeter in position.
5. Gradually close the shut-off valve of the pressure gauge and increase the hydraulic pressure then check whether or not the hydraulic pressure that activates the switch is the standard value.

Standard value: 1.5–2.0 MPa (213–284 psi)

6. Gradually open the shut-off valve and reduce the hydraulic pressure, then check whether or not the hydraulic pressure that deactivates the switch is the standard value.

Standard value: 0.7–2.0 MPa (100–284 psi)

7. Remove the special tools, and then tighten the pressure hose to the specified torque.
8. Bleed the system.

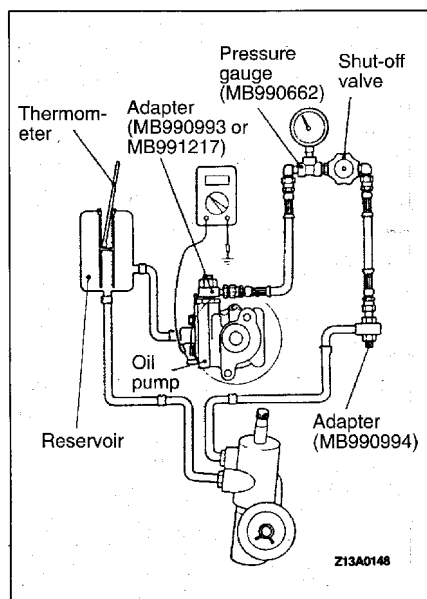
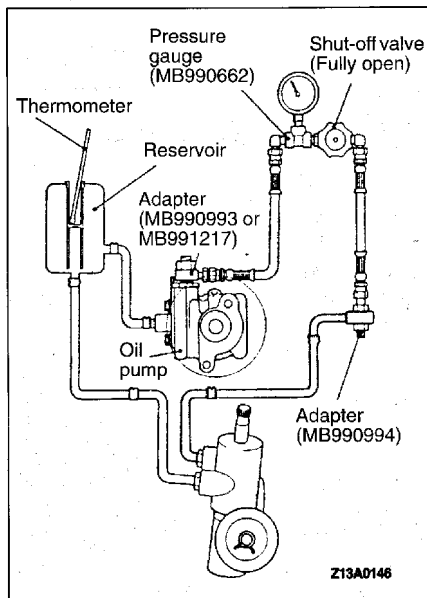

STEERING WHEEL AND SHAFT

REMOVAL AND INSTALLATION

<1993 models>

Post-installation Operation

- Steering Wheel Centering Inspection

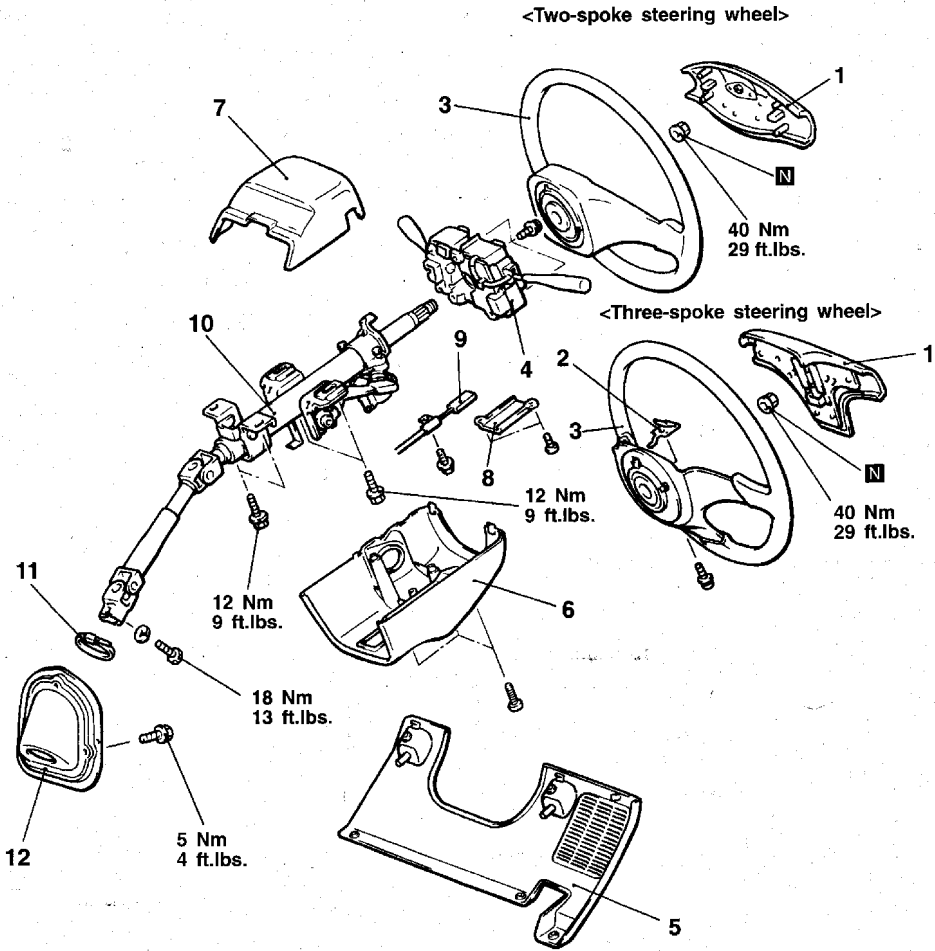

Z13S0107

Removal steps

1. Horn pad
2. Spring holder
3. Steering wheel
4. Column switch
5. Knee protector (Refer to GROUP 52A – Instrument Panel.)
6. Lower column cover

7. Upper column cover
8. Cover <A/T>
9. Connection for key interlock cable <A/T>
10. Steering column assembly
11. Band
12. Steering cover



<From 1994 models>

Post-installation Operation

- Steering Wheel Centering Inspection

CAUTION: SRS

Before removal of air bag module, refer to GROUP 52B – SRS Service Precautions and Air Bag Module and Clock Spring.

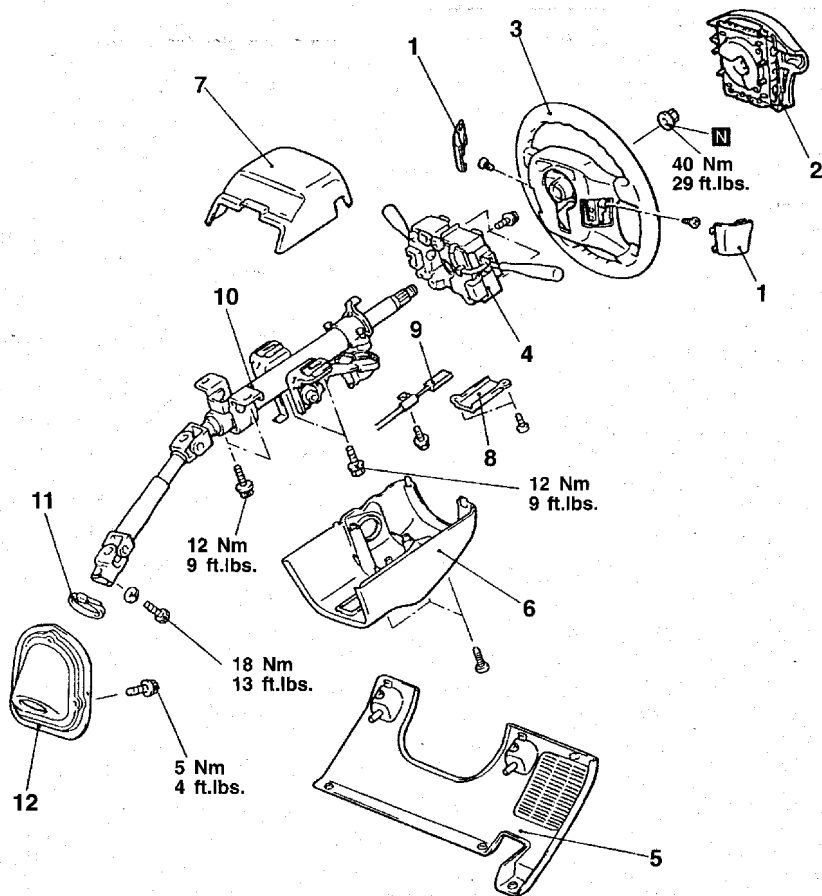

Z13S0123

Removal steps

1. Cover
2. Air bag module
(Refer to GROUP 52B – Air Bag Module and Clock Spring.)
3. Steering wheel
4. Column switch assembly
5. Knee protector (Refer to GROUP 52A – Instrument Panel.)
6. Lower column cover
7. Upper column cover
8. Cover <A/T>
9. Connection for key interlock cable <A/T>
10. Steering column assembly
11. Band
12. Steering cover

REMOVAL SERVICE POINTS**◀A▶ HORN PAD REMOVAL <3-SPOKE STEERING WHEEL>**

Remove the spring holder mounting screw from the reverse side of the steering wheel, and then remove the horn pad.

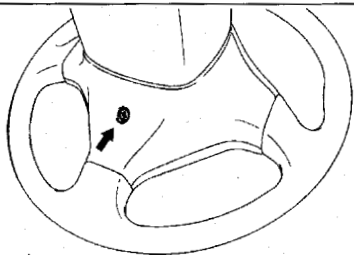

Z1390002

◀B▶ STEERING WHEEL REMOVAL

Using the special tool, remove the steering wheel.

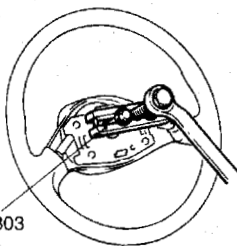

MB990803

Z1390005

INSTALLATION SERVICE POINT**▶A▶ SPRING HOLDER / HORN PAD INSTALLATION <3-SPOKE STEERING WHEEL>**

- (1) Install the spring holder on the steering wheel.
- (2) Insert the horn pad in the spring holder and install to the steering wheel while pushing on the upper side.

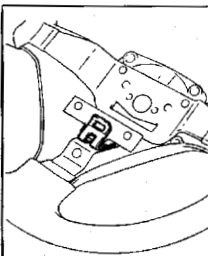

Z1390004



Z1390003

DISASSEMBLY AND REASSEMBLY

11000322

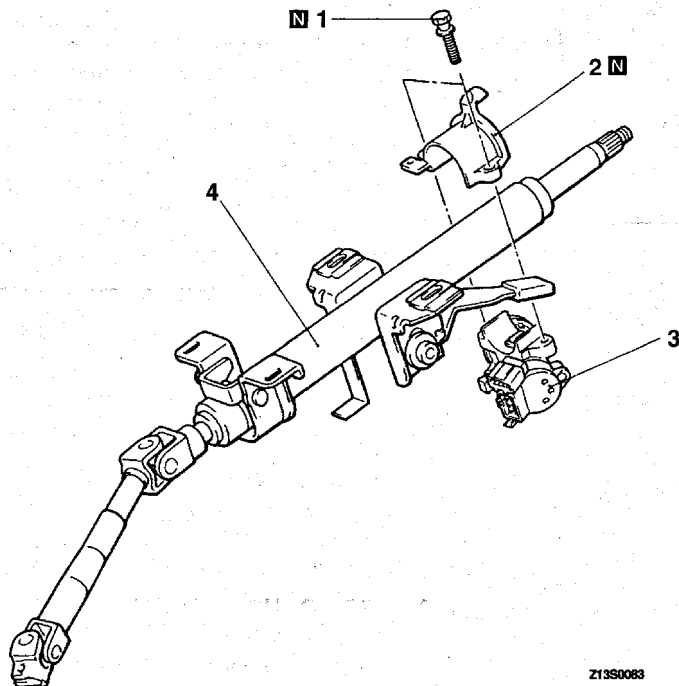

Z13S0083

Disassembly steps

1. Special bolt
2. Steering lock bracket
3. Steering lock cylinder assembly
4. Steering column assembly

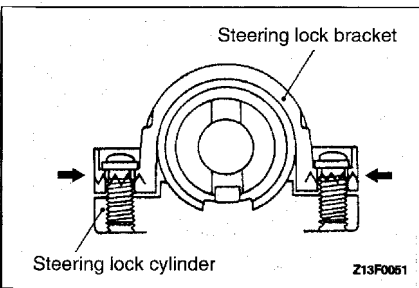
**DISASSEMBLY SERVICE POINT****◀A▶ SPECIAL BOLT / STEERING LOCK BRACKET / STEERING LOCK CYLINDER ASSEMBLY REMOVAL**

If it is necessary to remove the steering lock cylinder, use a hacksaw to cut the special bolts at the steering lock bracket side.

INSPECTION

- Check the universal joint for end play.
- Check for bent steering column assembly.
- Check for damaged or defective steering column.

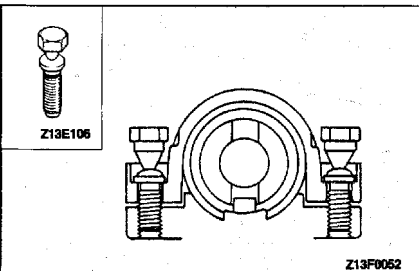
**REASSEMBLY SERVICE POINT****▶A◀ STEERING LOCK CYLINDER ASSEMBLY / STEERING LOCK BRACKET / SPECIAL BOLT INSTALLATION**

- (1) When installing the steering lock and steering lock bracket to the column tube, temporarily install the steering lock in alignment with the column boss.
- (2) After checking that the lock works properly, tighten the special bolts until the head twists off.

MANUAL STEERING GEAR BOX

REMOVAL AND INSTALLATION

Pre-removal Operation

- Centermember Removal (Refer to GROUP 32 – Engine Roll Stopper, Centermember.)
- Front Exhaust Pipe Removal (Refer to GROUP 15 – Exhaust Pipe and Main Muffler.)
- Turn the steering wheel to the left to move the rack to the right.

Post-installation Operation

- Front Exhaust Pipe Installation (Refer to GROUP 15 – Exhaust Pipe and Main Muffler.)
- Centermember Installation (Refer to GROUP 32 – Engine Roll Stopper, Centermember.)
- Steering Wheel Centering Inspection
- Front Wheel Alignment Adjustment (Refer to GROUP 33A – Service Adjustment Procedures.)

CAUTION: SRS

Before removal of steering gear box, refer to GROUP 52B – SRS, center front wheels and remove ignition key. Failure to do so may damage SRS clock spring and render SRS system inoperative, risking serious driver injury.

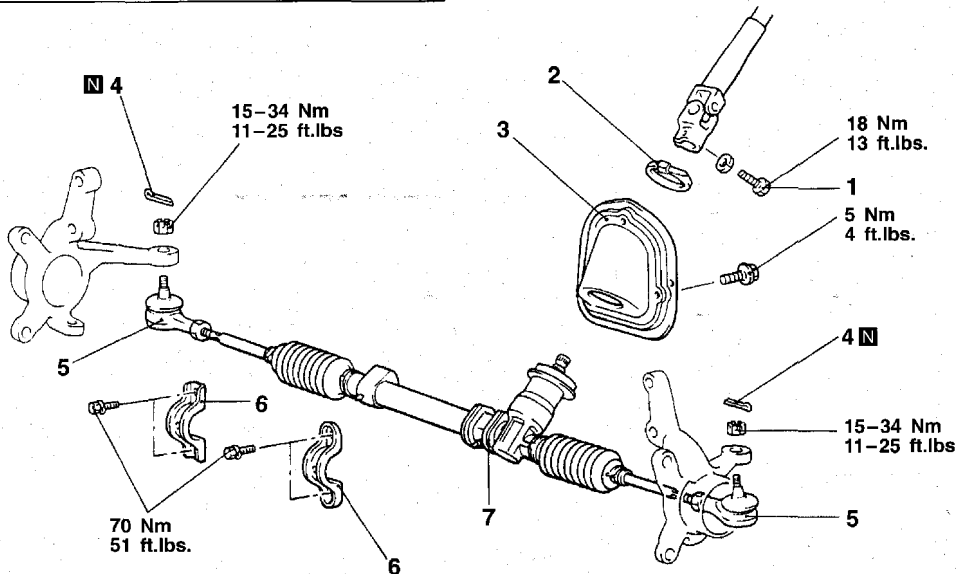

Removal steps

1. Joint assembly and gear box connecting bolt
2. Band
3. Steering cover
4. Cotter pin
5. Connection for tie-rod end and knuckle
6. Clamp
7. Gear box assembly



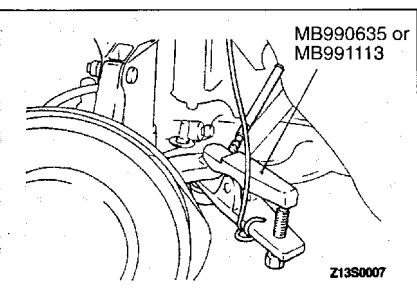

REMOVAL SERVICE POINTS

◀A▶ TIE-ROD END DISCONNECTION

Using the special tool, disconnect the tie-rod end from the knuckle.

Caution

1. Be sure to tie the cord of the special tool to a nearby part.
2. Loosen the nut but do not remove it.

◀B▶ GEAR BOX ASSEMBLY REMOVAL

Caution

When removing the gear box, pull it out carefully and slowly to avoid damaging the bellows and tie-rod end dust cover.

- (1) Move the gear box assembly to the right and pull out the left-side tie-rod from the fender shield.
- (2) Lower the left side of the gear box assembly and remove it.

INSPECTION

- Check the rubber parts for cracks and breakage.

GEAR BOX FOR TOTAL PINION PRELOAD

- (1) Install the special tools to the pinion.
- (2) Place the rack in the neutral condition, and then measure the total pinion preload (at a speed of one rotation every four to six seconds).

NOTE

Make measurements when rotation is to the left and to the right of the neutral position.

Standard value: 0.3–1.4 Nm (3–12 in.lbs.)

[Change in torque: 0.4 Nm (3 in.lbs.)]

NOTE

Measure the pinion preload through the whole stroke of the rack.

If the measured value is not within the standard range, first adjust the rack support cover, and then check the total pinion preload again.

If the total pinion preload cannot be adjusted to within the standard range by adjusting the rack support cover, check the rack support cover, rack support spring, rack support and replace any parts necessary.

TIE-ROD FOR SWING RESISTANCE

- (1) Give 10 hard swings to the tie-rod.
- (2) Measure the tie-rod swing resistance with a spring scale.

Standard value: 8–20 N (1.9–4.6 lbs.)

[2–5 Nm (17–43 in.lbs.)]

- (3) If the measured value exceeds the standard value, replace the tie-rod assembly.
- (4) Even if the measured value is below the standard value, the tie-rod which swings smoothly without excessive play may be used.

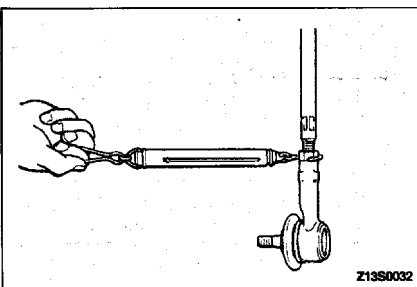
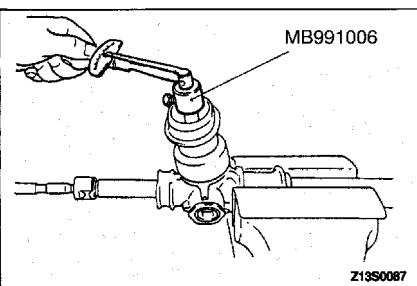

DISASSEMBLY AND REASSEMBLY

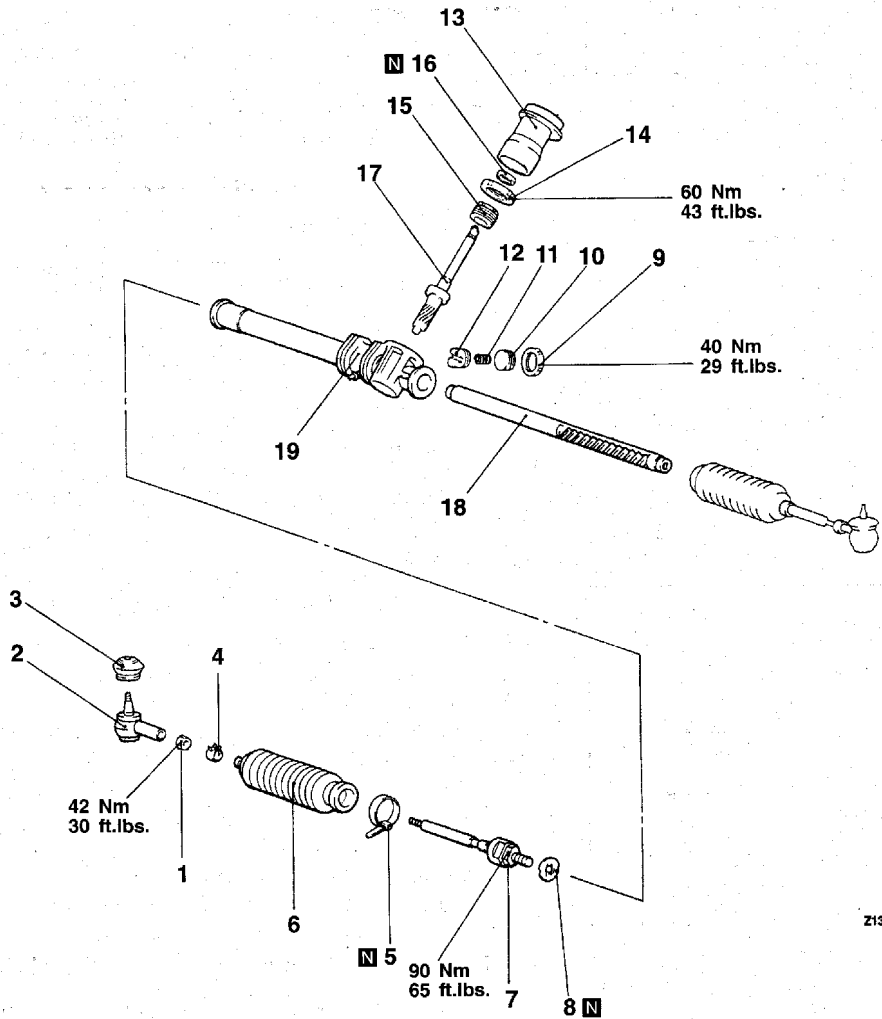

Z1390091

Disassembly steps



1. Tie-rod end lock nut
2. Tie-rod end
3. Dust cover
4. Bellows clip
5. Bellows band
6. Bellows
7. Tie-rod
8. Tab washer
9. Locking nut



● Adjustment of total pinion preload



10. Rack support cover
11. Rack support spring
12. Rack support
13. Joint cover
14. Locking nut
15. Top cover
16. Oil seal
17. Pinion
18. Rack
19. Gear housing

LUBRICATION AND SEALING POINTS

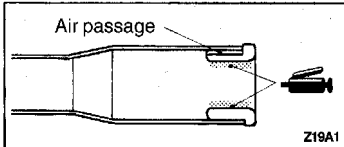

Caution: Take care that the applied grease does not obstruct the air passage of the rack bushing.

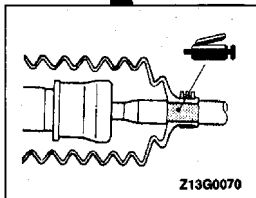
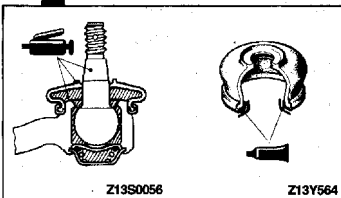
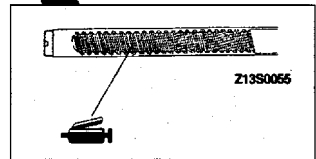
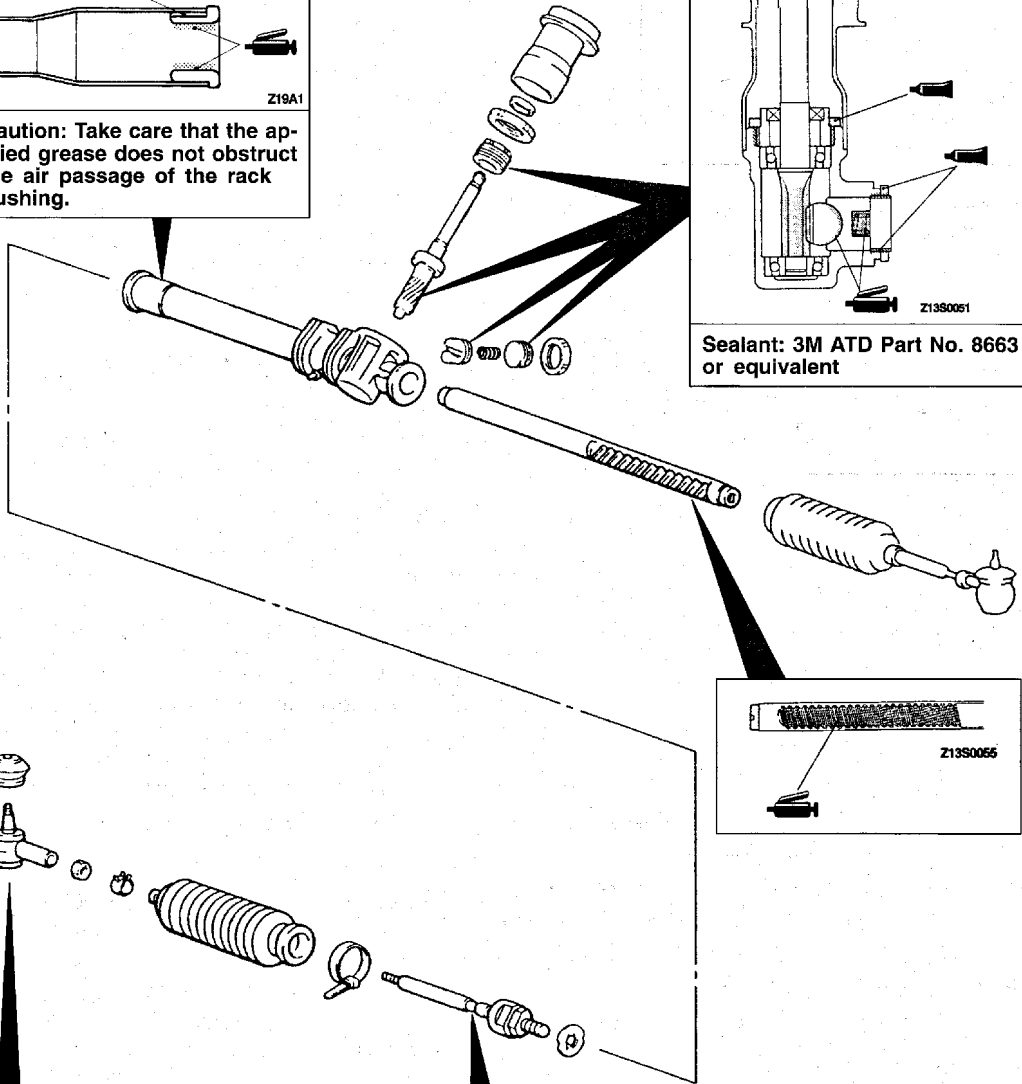
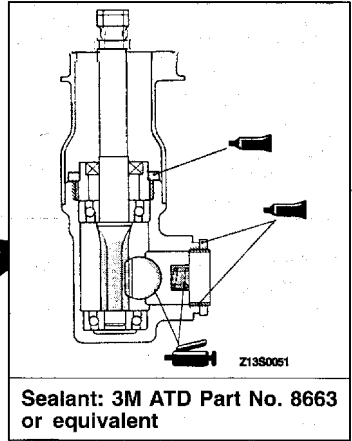

Sealant: 3M ATD Part No. 8663 or equivalent

Grease: Silicone grease

DISASSEMBLY SERVICE POINTS**◀A▶ RACK SUPPORT COVER REMOVAL**

Using the special tool, remove the rack support cover from the gear box.

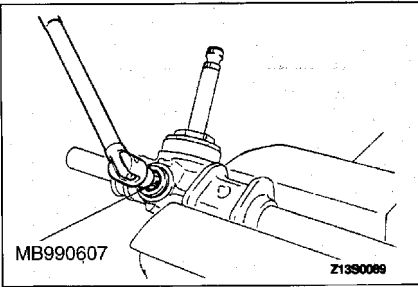
**◀B▶ RACK REMOVAL**

Pull out the rack from the gear housing in the direction shown in the illustration.

Caution

If the rack is pulled out in the wrong direction, the bushing in the gear box may be damaged by the rack threads.

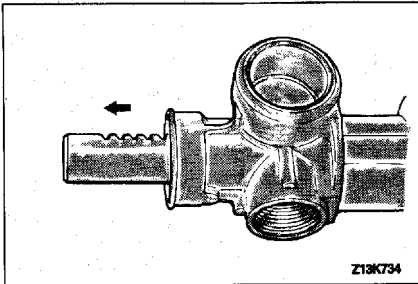
**INSPECTION**

- Check the rack support for uneven wear or damage.
- Check the rack support spring for deterioration.
- Check the rack pinion tooth surfaces for wear or damage.
- Check the ball bearings or pinion bushing for noise, uneven rotation, or damage.
- Check the rack bushing for damage.
- Check the dust cover for cracks or damage.

REASSEMBLY SERVICE POINTS**▶A◀ OIL SEAL INSTALLATION**

Using the special tool, press the oil seal into the top plug.

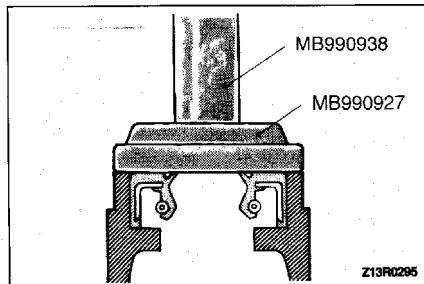
**▶B◀ TOTAL PINION PRELOAD ADJUSTMENT**

- (1) Position rack at its center and tighten rack support cover to 15 Nm (11 ft.lbs.).

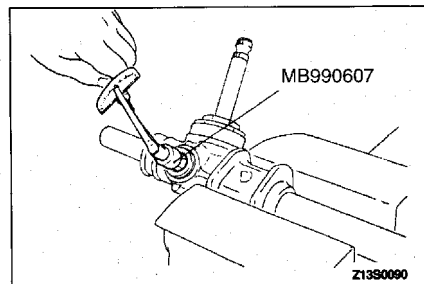

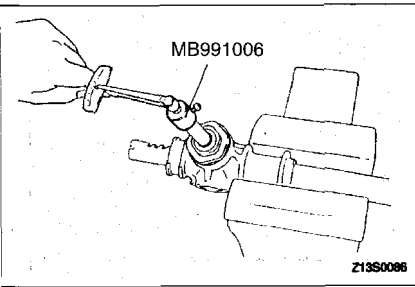

- (2) In neutral position, rotate pinion shaft clockwise one turn/4-6 seconds with special tool. Return rack support cover 30°–60° and adjust torque to the standard value.

Standard value: 0.3–1.4 Nm (3–12 in.lbs.)
[Torque variation: 0.4 Nm (3 in.lbs.)]

Caution

1. When adjusting, set the standard value at its highest value.
2. Assure no ratcheting or catching when operating rack towards the shaft direction.

NOTE

When it cannot be adjusted within the specified return angle, check rack support cover components or replace.

- (3) After adjusting, lock rack support cover with lock nut.

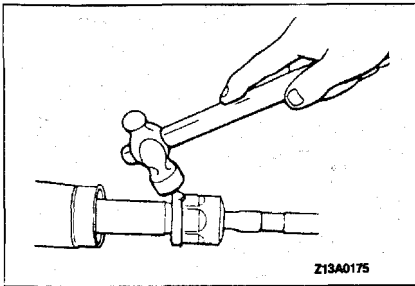

▶C◀ TAB WASHER / TIE-ROD INSTALLATION

After installing tie-rod to rack, fold tab washer end (2 locations) to tie-rod notch.

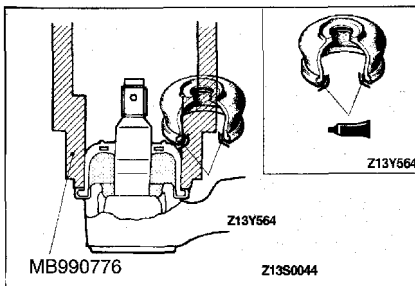

▶D◀ DUST COVER INSTALLATION

- (1) Pack dust cover interior with multipurpose grease.
- (2) Apply specified sealant to dust cover lip.

Specified sealant:

3M ATD Part No. 8663 or equivalent

- (3) Using the special tool, install the dust cover to the tie-rod end ball joint.

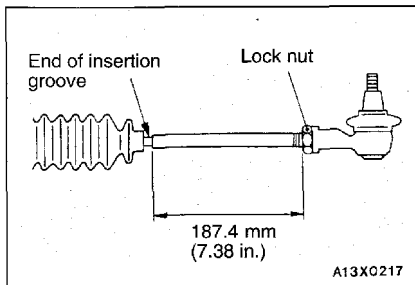

▶E◀ TIE-ROD END / TIE-ROD END LOCK NUT INSTALLATION

Screw in tie-rod end to have its right and left length as illustrated. Lock with lock nut.

NOTE

Fully tighten the lock nut after installing the gear box and adjusting the toe-in.

POWER STEERING GEAR BOX

REMOVAL AND INSTALLATION

Pre-removal Operation

- Power Steering Fluid Draining (Refer to P. 37A-11.)
- Centermember Removal (Refer to GROUP32 – Engine Roll Stopper, Centermember.)
- Front Exhaust Pipe Removal (Refer to GROUP 15 – Exhaust Pipe and Main Muffler.)
- Turn the steering wheel to the left to move the rack to the right.

CAUTION: SRS

Before removal of steering gear box, refer to GROUP 52B – SRS, center front wheels and remove ignition key. Failure to do so may damage SRS clock spring and render SRS system inoperative, risking serious driver injury.

Post-installation Operation

- Front Exhaust Pipe Installation (Refer to GROUP 15 – Exhaust Pipe and Main Muffler.)
- Centermember Installation (Refer to GROUP 32 – Engine Roll Stopper, Centermember.)
- Power Steering Fluid Supplying (Refer to P. 37A-11.)
- Power Steering Fluid Line Bleeding (Refer to P. 37A-12.)
- Steering Wheel Centering Inspection
- Front Wheel Alignment Adjustment (Refer to GROUP 33A – Service Adjustment Procedures.)

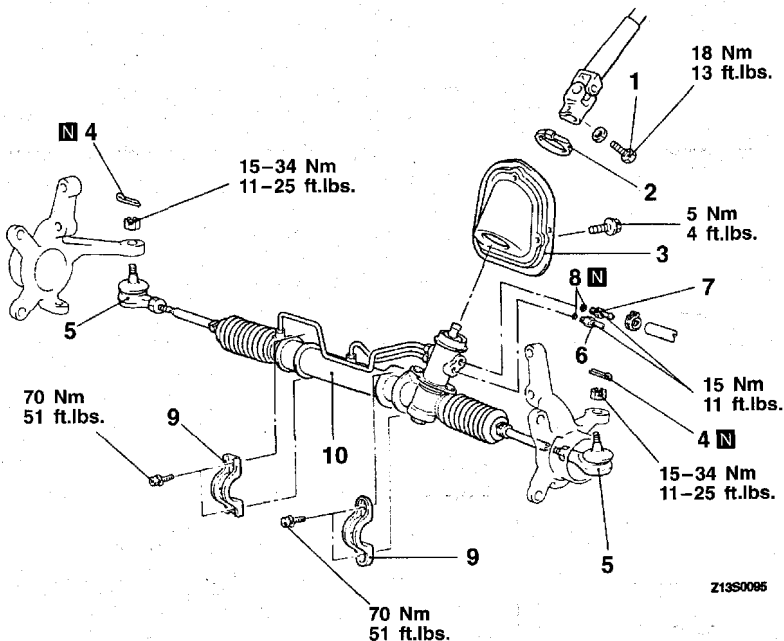

Z13S0086

Removal steps

1. Joint assembly and gear box connecting bolt
2. Band
3. Steering cover
4. Cotter pin
5. Connection for tie-rod end and knuckle
6. Pressure pipe
7. Return pipe
8. O-ring
9. Clamp
10. Gear box assembly

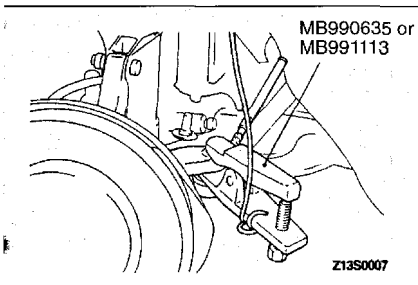

**REMOVAL SERVICE POINTS****◀A▶ TIE-ROD END DISCONNECTION**

Using the special tool, disconnect the tie-rod end from the knuckle.

Caution

1. Be sure to tie the cord of the special tool to a nearby part.
2. Loosen the nut but do not remove it.

◀B▶ GEAR BOX ASSEMBLY REMOVAL**Caution**

Be careful not to damage the bellows and the tie-rod end dust cover when removing the gear box assembly.

- (1) Move the gear box assembly to the right and pull out the left side tie-rod from the fender shield.
- (2) Lower the left side of the gear box assembly and remove it.

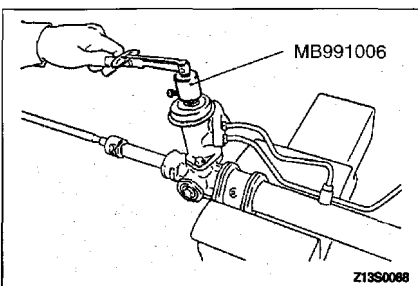
**INSPECTION**

- Check the rubber parts for cracks and breakage.

GEAR BOX FOR TOTAL PINION PRELOAD

Using the special tools, rotate the pinion gear at the rate of one rotation in approximately 4 to 6 seconds to check the total pinion preload.

Standard value: 0.6–1.4 Nm (5–12 in.lbs.)

[Change in torque: 0.4 Nm (3 in.lbs.)]

NOTE

Measure the pinion preload through the whole stroke of the rack.

If the measured value is not within the standard range, first adjust the rack support cover, and then check the total pinion starting torque again.

If the total pinion starting torque cannot be adjusted to within the standard range by adjusting the rack support cover, check the rack support cover, rack support spring, rack support and replace any parts necessary.

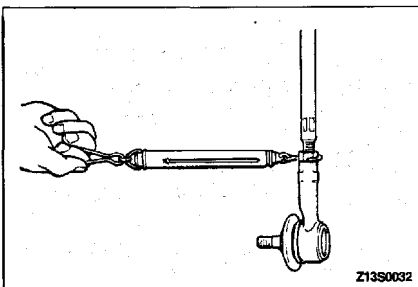
**TIE-ROD FOR SWING RESISTANCE**

- (1) Give 10 hard swings to the tie-rod.
- (2) Measure the tie-rod swing resistance with a spring scale.

Standard value: 8–20 N (1.9–4.4 lbs.)

[2–5 Nm (17–43 in.lbs.)]

- (3) If the measured value exceeds the standard value, replace tie-rod assembly.
- (4) Even if the measured value is below the standard value, the tie-rod which swings smoothly without excessive play may be used.

DISASSEMBLY AND REASSEMBLY

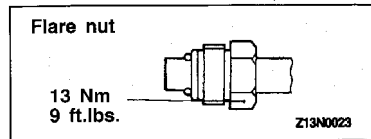
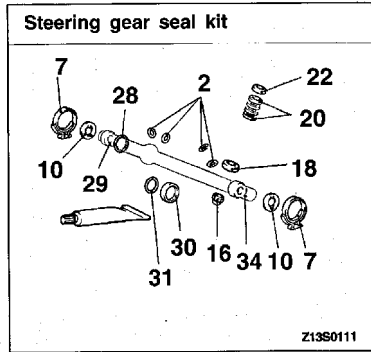
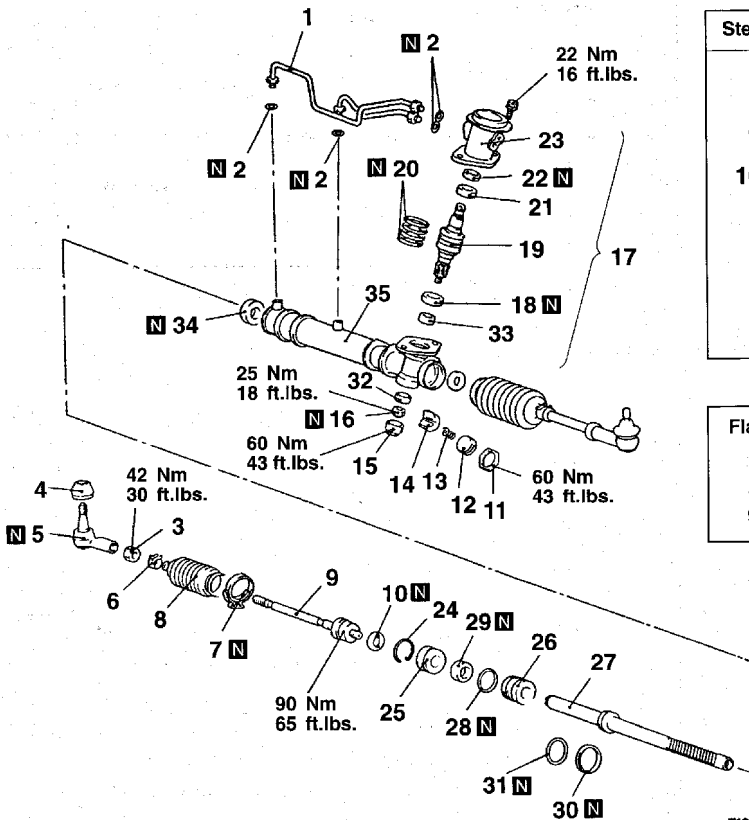

Z13S0110

Disassembly steps

- 1. Feed pipe
 - 2. O-ring
 - 3. Tie-rod end lock nut
 - 4. Tie-rod end
 - 5. Dust cover
 - 6. Bellows clip
 - 7. Bellows band
 - 8. Bellows
 - 9. Tie-rod
 - 10. Tab washer
 - 11. Locking nut
 - 12. Rack support cover
 - 13. Rack support spring
 - 14. Rack support
 - 15. End plug
 - 16. Self-locking nut
 - 17. Valve housing assembly
- Total pinion preload adjustment

- 18. Oil seal
- 19. Pinion and valve assembly
- 20. Seal ring
- 21. Ball bearing
- 22. Oil seal
- 23. Valve housing
- 24. Circlip
- 25. Rack stopper
- 26. Rack bushing
- 27. Rack
- 28. O-ring
- 29. Oil seal
- 30. Seal ring
- 31. O-ring
- 32. Ball bearing
- 33. Needle roller bearing
- 34. Oil seal
- 35. Rack housing

LUBRICATION AND SEALING POINTS

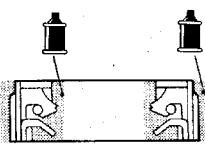

Z13S0075

Fluid: Automatic transmission fluid "DEXRON II"

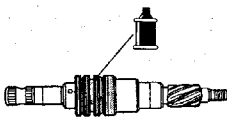

Z13C0026

Fluid: Automatic transmission fluid "DEXRON II"

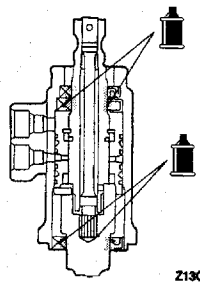

Z13C0026

Fluid: Automatic transmission fluid "DEXRON II"

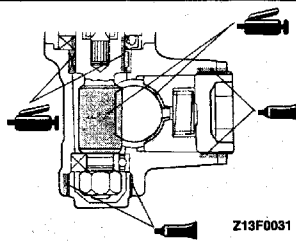

Z13F0031

Sealant: 3M ATD Part No. 8663 or equivalent

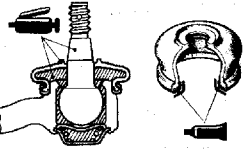

Z13S0056 Z13Y564

Sealant: 3M ATD Part No. 8663 or equivalent

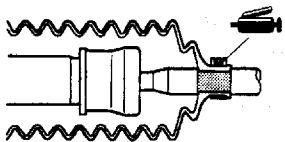

Y13G0070

Grease: Silicone grease

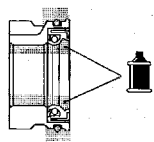

Z13N0019

Fluid: Automatic transmission fluid "DEXRON II"

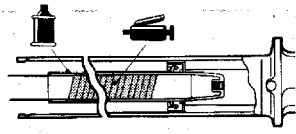

Z13S0072

Fluid: Automatic transmission fluid "DEXRON II"

DISASSEMBLY SERVICE POINTS

◀A▶ RACK SUPPORT COVER REMOVAL

Using the special tool, remove the rack support cover from the gear box.

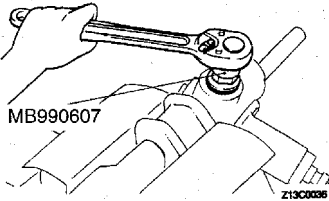

◀B▶ OIL SEAL / PINION AND VALVE ASSEMBLY REMOVAL

Using a plastic hammer, gently tap the pinion to remove it.

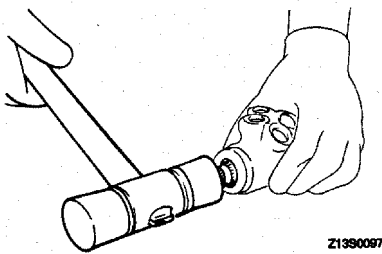

◀C▶ SEAL RING REMOVAL

Cut the seal ring and remove it from the pinion and valve assembly and the rack.

Caution

When cutting the seal ring, be careful not to damage the pinion and valve assembly or the rack.

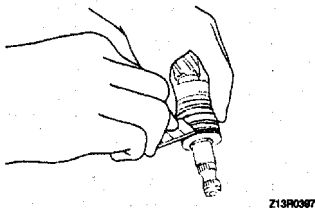

◀D▶ BALL BEARING / OIL SEAL REMOVAL

Using a socket, remove the oil seal and the ball bearing from the valve housing simultaneously.

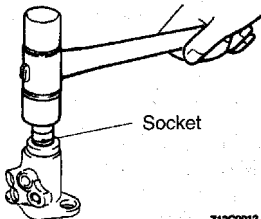

◀E▶ CIRCLIP REMOVAL

- (1) Turn the rack stopper clockwise until the end of the circlip comes out of the slot in the rack housing.
- (2) Turn the rack stopper counterclockwise to remove the circlip.

Caution

Note that if the rack stopper is first turned counterclockwise, the circlip will get caught in the slot in the housing and the rack stopper will not turn.

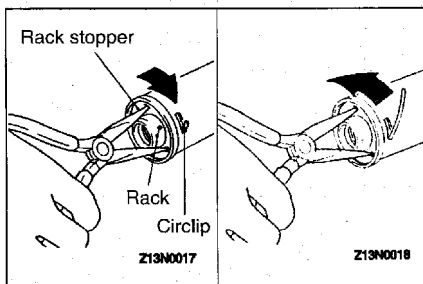

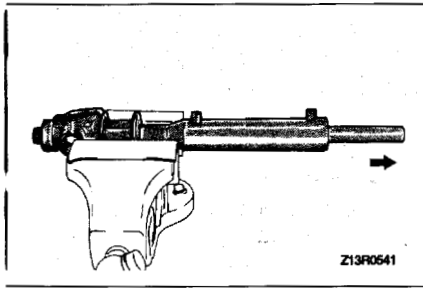
**◀F▶ RACK REMOVAL**

Pull out the rack slowly.

At this time also take out the rack stopper and the rack bushing simultaneously.

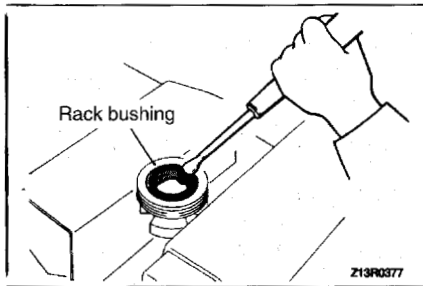
**◀G▶ OIL SEAL REMOVAL**

Partially bend oil seal and remove from rack bushing.

Caution

Do not damage oil seal press fitting surface.

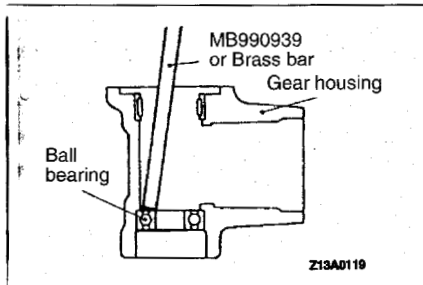
**◀H▶ BALL BEARING REMOVAL**

Use a brass bar or special tool to remove the ball bearing from the gear housing.

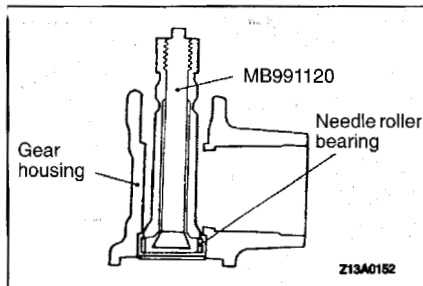
**◀I▶ NEEDLE ROLLER BEARING REMOVAL**

Use the special tool to remove the needle roller bearing from the rack housing.

Caution

Do not open special tool excessively to prevent damaging housing interior.

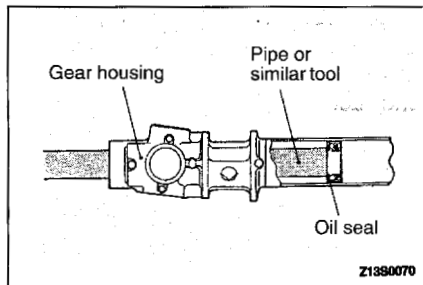
**◀J▶ OIL SEAL REMOVAL**

Use a piece of pipe or similar tool to remove the oil seal from the gear housing.

Caution

Be careful not to damage the inner surface of the rack cylinder of the gear housing.

INSPECTION**RACK**

- Check the rack tooth surfaces for damage or wear.
- Check the oil seal contact surfaces for uneven wear.
- Check the rack for bends.

PINION AND VALVE ASSEMBLY

- Check the pinion gear tooth surfaces for damage or wear.
- Check for worn or defective seal ring.

BEARING

- Check for roughness or abnormal noise during bearing operation.
- Check the bearing for play.
- Check the needle roller bearings for roller slip-off.

OTHERS

- Check the cylinder inner surface of the rack housing for damage.
- Check the boots for damage, cracking or deterioration.
- Check the rack support for uneven wear or dents.
- Check the rack bushing for uneven wear or damage.

REASSEMBLY SERVICE POINTS**▶◀ OIL SEAL INSTALLATION**

Using the special tool, install the oil seal in the rack housing.

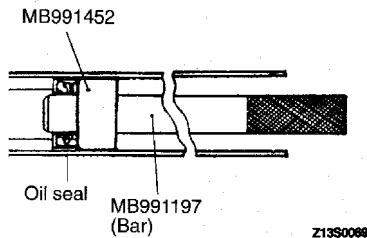
**▶◀ NEEDLE ROLLER BEARING / BALL BEARING INSTALLATION**

Using the special tool, install the needle roller bearing and the ball bearing in the rack housing.

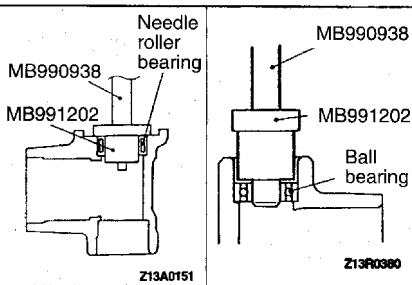
**▶◀ OIL SEAL INSTALLATION**

Apply specified fluid to the outer surface of the oil seal. Press-fit the oil seal using the special tool until it is flush with the bushing end face.

Specified fluid:

Automatic transmission fluid "DEXRON II"

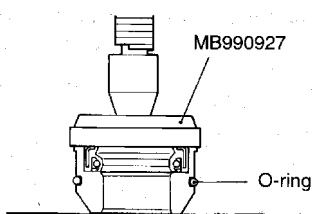

►D◄ RACK INSTALLATION

- (1) Apply a coating of multipurpose grease to the rack teeth face.

Caution

Do not close the vent hole in the rack with grease.

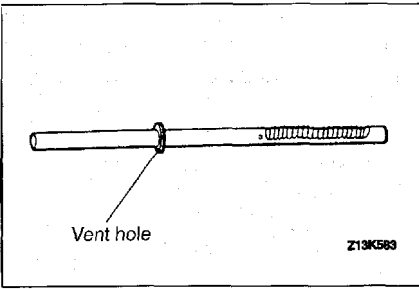

- (2) Cover rack serrations with special tool.
- (3) Apply specified fluid on special tool.

Specified fluid:

Automatic transmission fluid "DEXRON II"

- (4) Match oil seal center with rack to prevent retainer spring from slipping and slowly insert rack from power cylinder side.

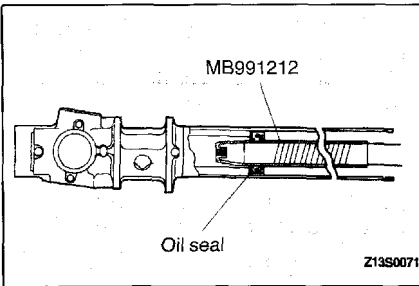

►E◄ RACK BUSHING INSTALLATION

- (1) Apply specified fluid to the oil seal inner surface and the O-ring.

Specified fluid:

Automatic transmission fluid "DEXRON II"

- (2) Wrap the rack end with vinyl tape, and push the rack bushing onto the rack.

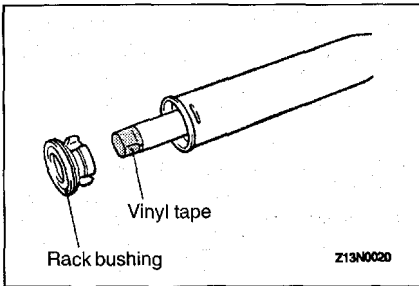

►F◄ CIRCLIP INSTALLATION

- Insert circlip to rack stopper hole through cylinder hole. Turn rack stopper clockwise and insert circlip firmly.

Caution

Insert circlip to rack stopper hole while turning rack stopper clockwise.

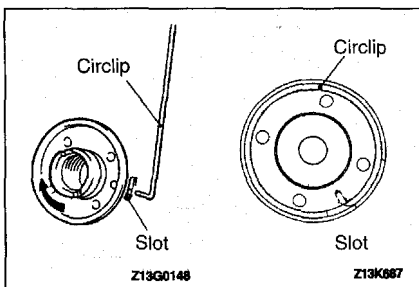

►G◄ OIL SEAL INSTALLATION

- Apply a coating of the specified fluid to the outside of the oil seal. Using the special tools, press the oil seal into the valve housing.

Specified fluid:

Automatic transmission fluid "DEXRON II"

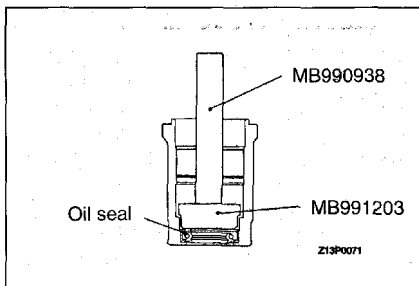

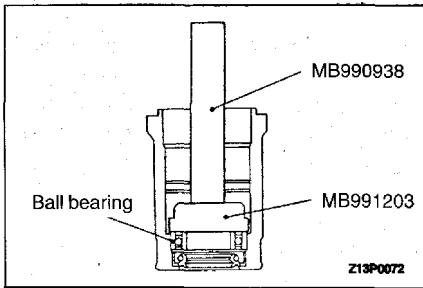

►H◄ BALL BEARING INSTALLATION

Apply a coating of the specified fluid to the outside of the ball bearing. Using the special tools, press the ball bearing into the valve housing.

Specified fluid:

Automatic transmission fluid "DEXRON II"

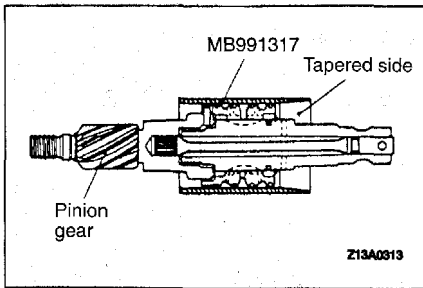

►I◄ SEAL RING INSTALLATION

- (1) Knead the seal ring to soften it.
- (2) Apply the specified fluid to the seal ring, and install to the rack groove.

Specified fluid:

Automatic transmission fluid "DEXRON II"

- (3) Insert the tapered side of the special tool from the pinion gear side, and compress the seal ring.

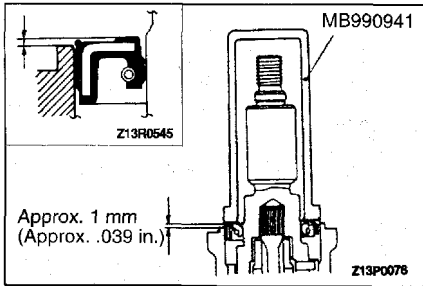

►J◄ OIL SEAL INSTALLATION

Using the special tool, press the oil seal into the valve housing.

Caution

In order to eliminate a seal malfunction at the valve housing alignment surface, the upper surface of the oil seal should project outward approximately 1 mm (.039 in.) from the housing edge surface.

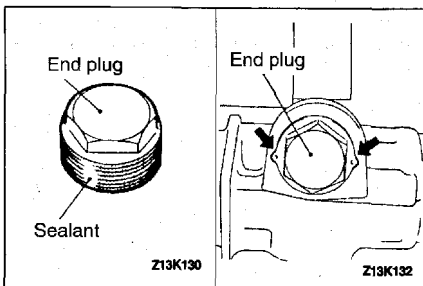

►K◄ END PLUG INSTALLATION

- (1) Apply the specified sealant to the threaded part of the end plug.

Specified sealant:

3M ATD Part No. 8663 or equivalent

- (2) Secure the threaded portion of the end plug at two places by using a punch.

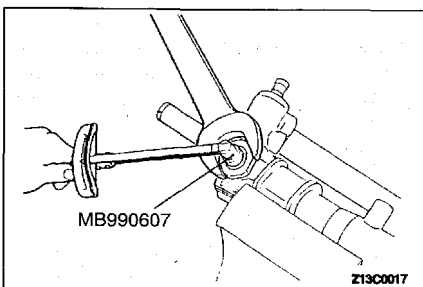

►L◄ TOTAL PINION PRELOAD ADJUSTMENT

- (1) Position rack at its center. With special tool, tighten rack support cover to 15 Nm (11 ft.lbs.).
- (2) In neutral position, rotate pinion shaft clockwise one turn/4-6 seconds with special tool. Return rack support cover 30°–60° and adjust torque to the standard value.

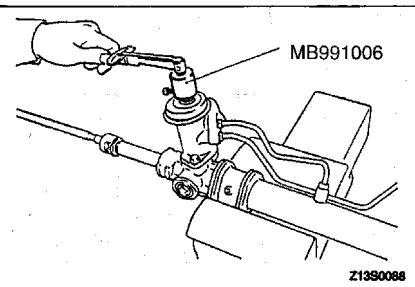

- (3) Using the special tool, rotate the pinion gear at the rate of one rotation in approximately 4 to 6 seconds to check the total pinion preload.

Standard value: 0.6–1.4 Nm (5–12 in.lbs.)
[Change in torque: 0.4 Nm (3 in.lbs.)]

Caution

1. When adjusting, set the standard value at its highest value.
2. Assure no ratcheting or catching when operating rack towards the shaft direction.

NOTE

When it cannot be adjusted within the specified return angle, check rack support cover components or replace.

- (4) After adjusting, lock rack support cover with lock nut.

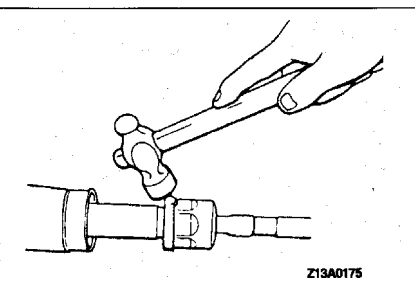

▶◀TAB WASHER / TIE ROD INSTALLATION

After installing tie-rod to rack, fold tab washer end (2 locations) to tie rod notch.

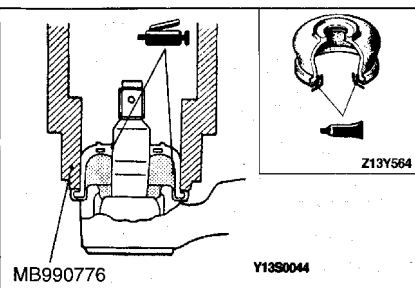

▶◀DUST COVER INSTALLATION

- (1) Pack dust cover interior with multipurpose grease.
- (2) Apply specified sealant to dust cover lip.

Specified sealant:

3M ATD Part No. 8663 or equivalent

- (3) Using the special tool, install the dust cover to the tie-rod end ball joint.

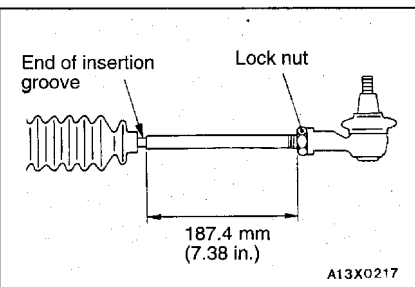

▶◀TIE-ROD END / TIE-ROD END LOCK NUT INSTALLATION

Screw in tie-rod end to have its right and left length as illustrated. Lock with lock nut.

NOTE

Fully tighten the lock nut after installing the gear box and adjusting the toe-in.

POWER STEERING OIL PUMP

REMOVAL AND INSTALLATION

Pre-removal Operation

- Power Steering Fluid Draining (Refer to P. 37A-11.)

Post-installation Operation

- Power Steering Fluid Supplying
- Drive-belt Tension Adjustment (Refer to GROUP 11 – Service Adjustment Procedures.)
- Power Steering Fluid Line Bleeding (Refer to P. 37A-12.)
- Oil Pump Pressure Test (Refer to P. 37A-13.)

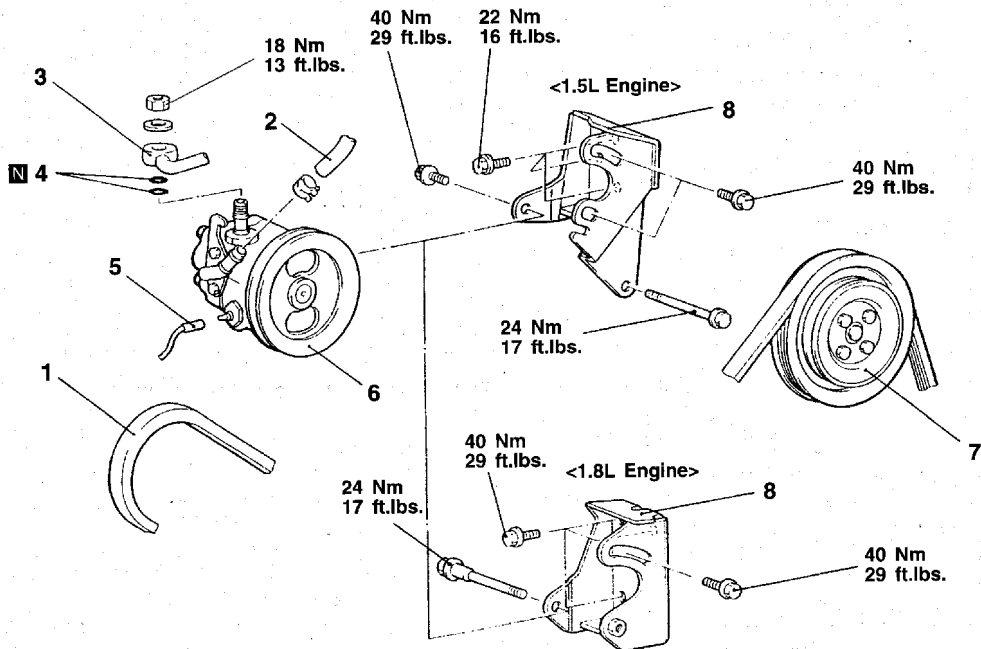

Z13S0096

Removal steps

1. Drive belt (for power steering)
2. Suction hose
3. Pressure hose
4. O-ring



5. Pressure switch connector
6. Oil pump
7. Water pump pulley (Refer to GROUP 11 – Timing Belt.)
8. Oil pump bracket

INSPECTION

- Check the drive belt for cracks.
- Check the pulley assembly for uneven rotation.

INSTALLATION SERVICE POINTS**▶A◀ OIL PUMP INSTALLATION <1.8L Engine>**

For vehicles with air conditioning, install the oil pump to the bracket so that it is in a position towards the front, and adjust the belt tension using the air conditioning tension pulley.

(Refer to GROUP 11 – Service Adjustment Procedures.)

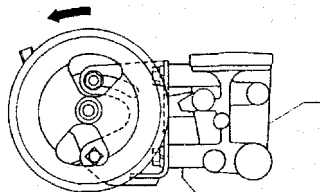

Z13S0008

▶B◀ PRESSURE HOSE INSTALLATION

Connect the pressure hose so that its notch part contacts the suction connector.

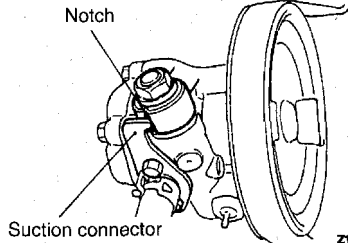

Z13C0038

DISASSEMBLY AND REASSEMBLY

<Up to Nov. 1995>

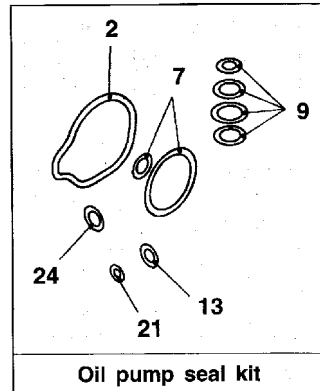
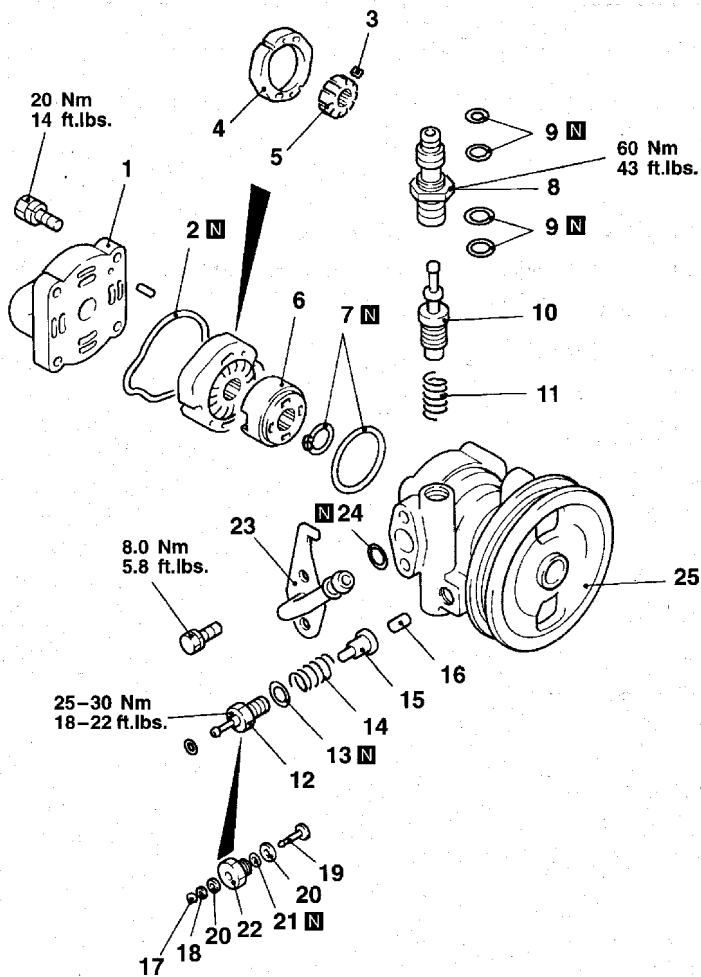

Oil pump seal kit

Disassembly steps

- 1. Pump cover
- 2. O-ring
- F** 3. Vanes
- E** 4. Cam ring
- D** 5. Rotor
- C** 6. Side plate
- A** 7. O-ring
- A** 8. Connector
- A** 9. O-ring
- 10. Flow control valve
- 11. Flow control spring
- 12. Terminal assembly
- A** 13. O-ring

- B** 14. Spring
- 15. Plunger
- 16. Piston rod
- 17. Snap ring
- 18. Washer
- 19. Terminal
- 20. Insulator
- A** 21. O-ring
- 22. Plug
- A** 23. Suction connector
- A** 24. O-ring
- 25. Oil pump body

Caution
Do not disassemble the flow control valve.

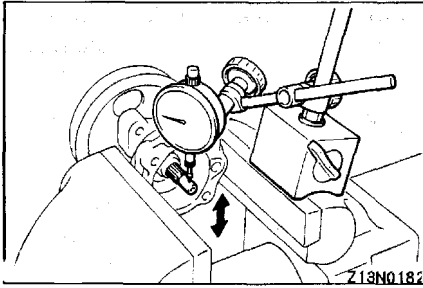

INSPECTION

CLEARANCE BETWEEN SHAFT AND PUMP BODY

- (1) Place the dial gauge against the end of the pulley assembly's shaft.
- (2) Move the pulley assembly up and down and measure the play.

Limit: 0.1 mm (.004 in.)

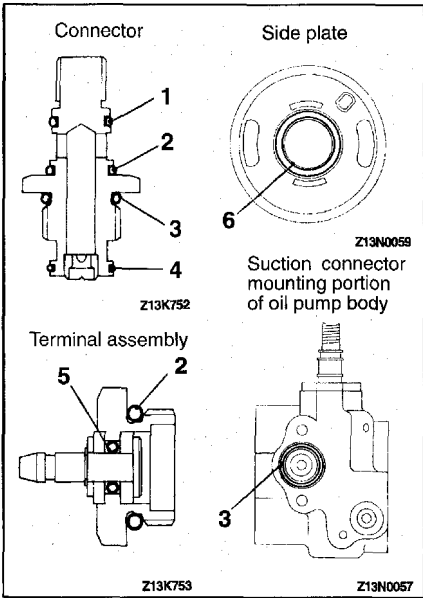

REASSEMBLY SERVICE POINTS

▶A◀ O-RINGS INSTALLATION

Apply specified fluid on O-rings to install.

No.	I.D. × Width mm (in.)
1	11 × 1.9 (.433 × .075)
2	13 × 1.9 (.512 × .075)
3	17.8 × 2.4 (.701 × .094)
4	13.5 × 1.5 (.531 × .059)
5	3.8 × 1.9 (.150 × .075)
6	16.8 × 2.4 (.661 × .094)

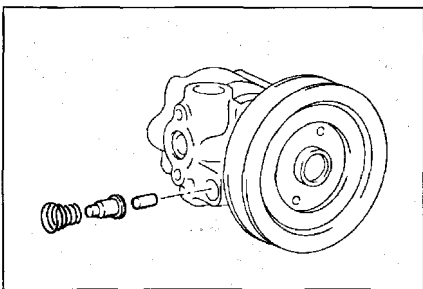

▶B◀ SPRING INSTALLATION

Fit the spring to the oil pump body with the larger diameter end at the terminal assembly side.

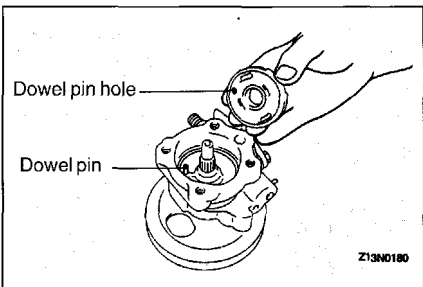

▶C◀ SIDE PLATE INSTALLATION

Line up the dowel pin hole of the side plate with the dowel pin of the pump body when installing the side plate.

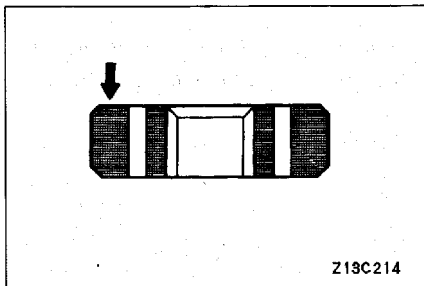

►D◄ ROTOR INSTALLATION

Install the rotor to the pulley assembly so that the rotor's punch mark is at the pump cover side.

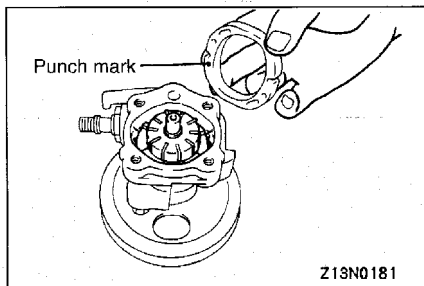

►E◄ CAM RING INSTALLATION

Install the cam ring with the punch mark facing the side plate.

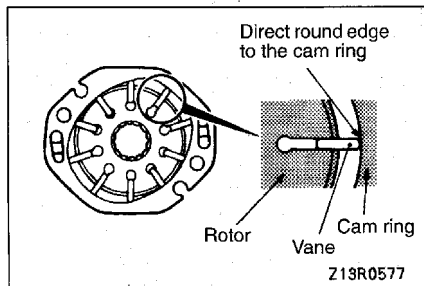

►F◄ VANES INSTALLATION

Install the vanes on the rotor, paying close attention to the installation direction.

DISASSEMBLY AND REASSEMBLY

<From Dec. 1995>

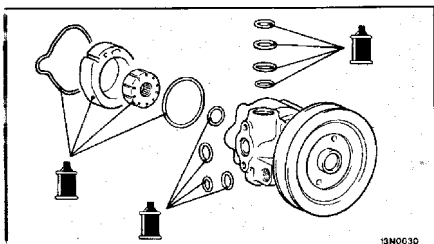

Fluid: Automatic transmission fluid
"DEXRON II"

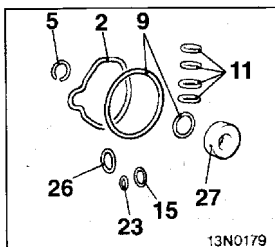

Oil pump seal kit

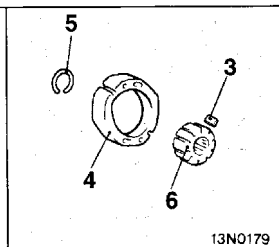

Oil pump cartridge kit

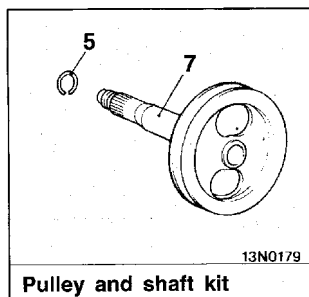
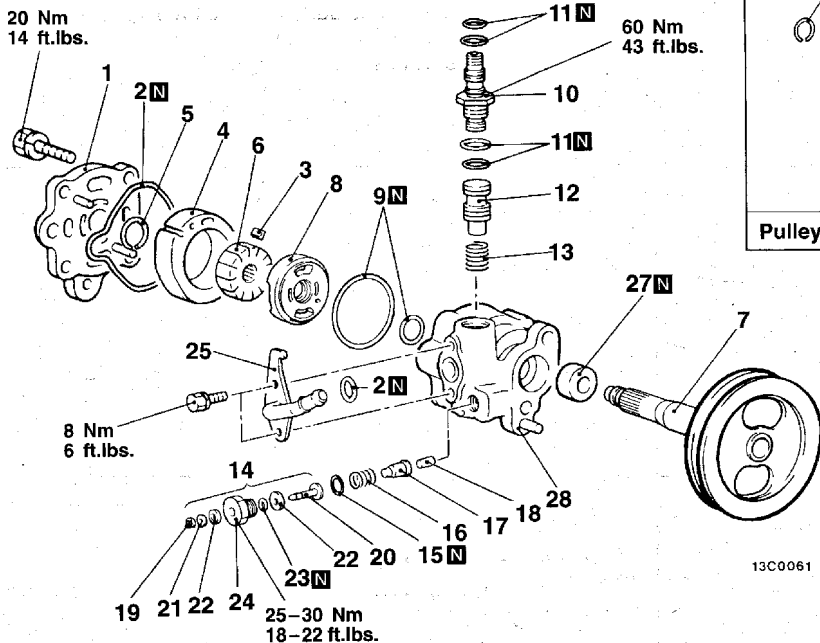

Pulley and shaft kit

Disassembly steps

- 1. Pump cover
- 2. O-ring
- 3. Vanes
- 4. Cam ring
- 5. Snap ring
- 6. Rotor
- 7. Pulley assembly
- 8. Side plate
- 9. O-ring
- 10. Connector
- 11. O-ring
- 12. Flow control valve
- 13. Flow control spring
- 14. Terminal assembly
- 15. O-ring

- ▶C◀ 16. Spring
- ▶C◀ 17. Plunger
- ▶C◀ 18. Piston rod
- ▶C◀ 19. Snap ring
- ▶C◀ 20. Terminal
- ▶C◀ 21. Washer
- ▶B◀ 22. Insulator
- ▶B◀ 23. O-ring
- ▶B◀ 24. Plug
- ▶B◀ 25. Suction connector
- ▶B◀ 26. O-ring
- ▶A◀ 27. Oil seal
- ▶A◀ 28. Oil pump body

Caution
Do not disassemble the flow control valve.

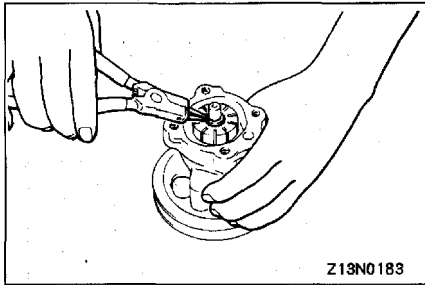

DISASSEMBLY SERVICE POINT

◀▶ SNAP RING REMOVAL

Remove the snap ring from the shaft (pulley assembly) with the snap ring plier and separate the rotor from the shaft.

Caution

Do not try to disassemble the pulley; it is press-fit onto the shaft.

INSPECTION

- Check the flow control valve for clogging.
- Check the pulley assembly for wear or damage.
- Check the groove of rotor and vane for “Stepped” wear.
- Check the contact surface of cam ring and vanes for “Stepped” wear.
- Check the vanes for damage.

CLEARANCE BETWEEN SHAFT AND PUMP BODY

- (1) Place the dial gauge against the end of the pulley assembly's shaft.
- (2) Move the pulley assembly up and down and measure the play.

Limit: 0.1 mm (.004 in.)

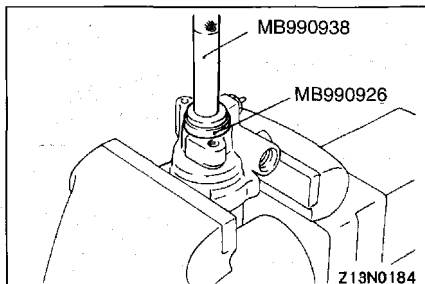
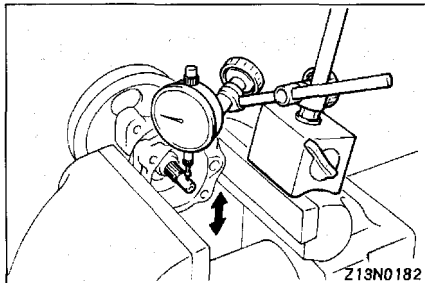

REASSEMBLY SERVICE POINTS

▶◀ OIL SEAL INSTALLATION

Using the special tools, drive the oil seal into the pump body.

►B◄ O-RINGS INSTALLATION

Apply specified fluid on O-ring to install.

No.	I.D. × Width mm (in.)
1	11 × 1.9 (.433 × .075)
2	13 × 1.9 (.512 × .075)
3	17.8 × 2.4 (.701 × .094)
4	13.5 × 1.5 (.531 × .059)
5	3.8 × 1.9 (.150 × .075)
6	16.8 × 2.4 (.661 × .094)

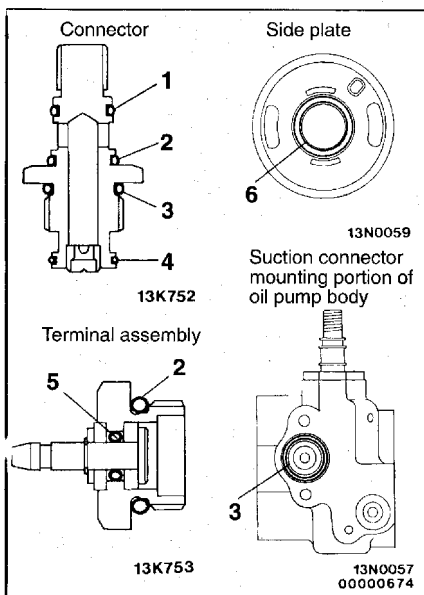

►C◄ SPRING INSTALLATION

Fit the spring to the oil pump body with the larger-diameter end at the terminal assembly side.

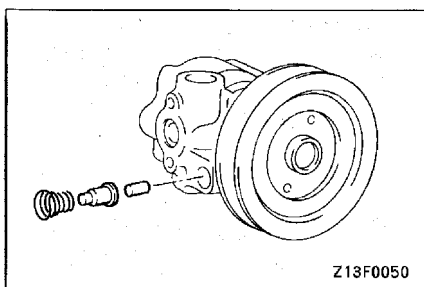

►D◄ SIDE PLATE INSTALLATION

Line up the dowel pin hole of the side plate with the dowel pin of the pump body when installing the side plate.

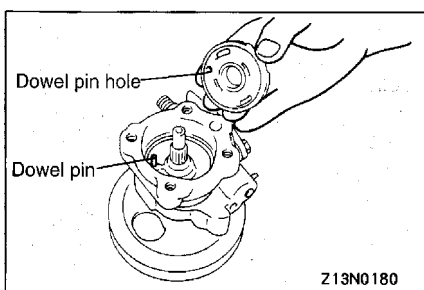

►E◄ ROTOR INSTALLATION

Install the rotor to the pulley assembly so that the rotor's punch mark is at the pump cover side.

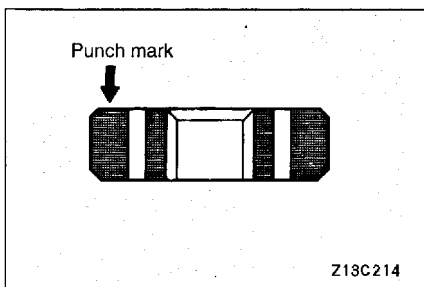

►F◄ SNAP RING INSTALLATION

- (1) Install the snap ring with the snap ring plier.

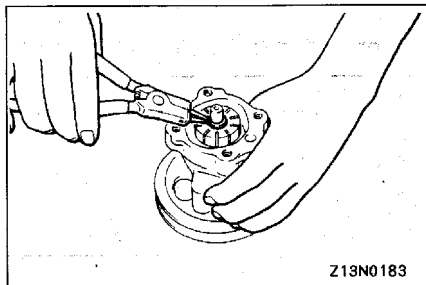

- (2) After installation of the snap ring, lift the rotor and check that the snap ring has entered the countersunk part.

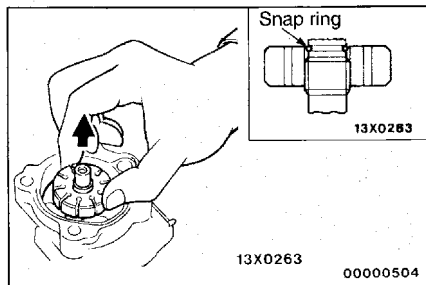

►G◄ CAM RING INSTALLATION

- Install the cam ring with the punch mark facing the side plate.

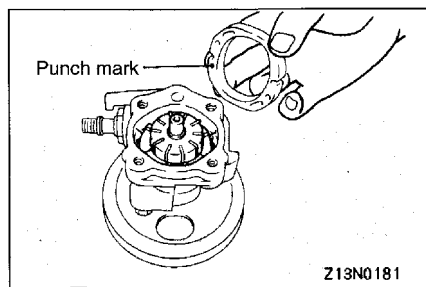

►H◄ VANES INSTALLATION

- Install the vanes on the rotor, paying close attention to the installation direction.

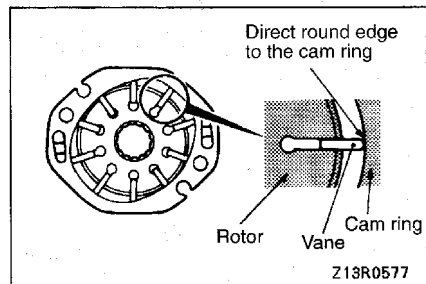

POWER STEERING HOSES

REMOVAL AND INSTALLATION

Pre-removal Operation

- Power Steering Fluid Draining (Refer to P. 37A-11.)
- Front Bumper Removal (Refer to GROUP 51 – Front Bumper.)

Post-installation Operation

- Front Bumper Installation (Refer to GROUP 51 – Front Bumper.)
- Power Steering Fluid Supplying
- Power Steering Fluid Line Bleeding (Refer to P. 37A-12.)

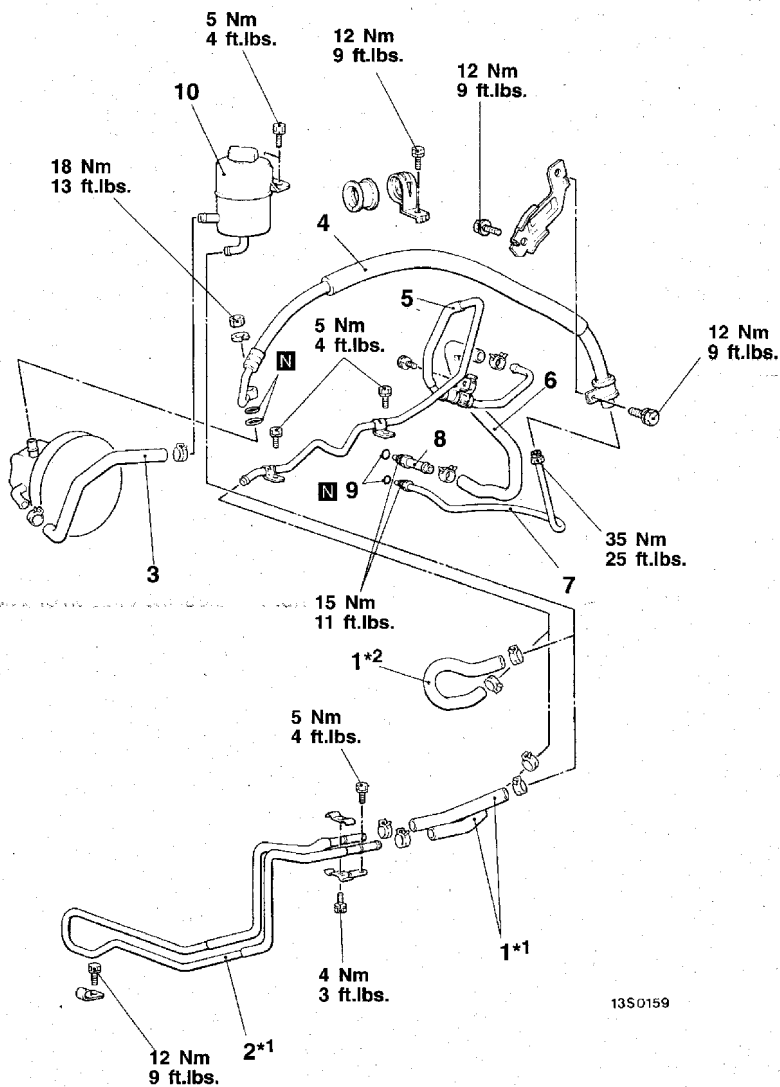

13S0159

Removal steps

1. Return hose
2. Cooler pipe
3. Suction hose
4. Pressure pipe
5. Return pipe
6. Return hose

7. Pressure pipe
8. Return pipe
9. O-ring
10. Oil reservoir



NOTE

- *1: Vehicles built up to June 1994.
- *2: Vehicles built from July 1994.

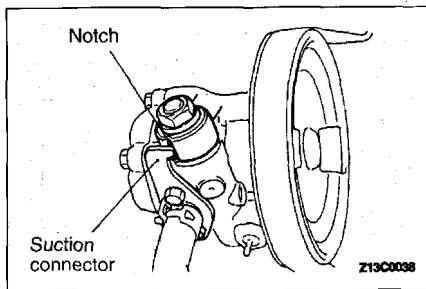

INSTALLATION SERVICE POINT

▶A◀ PRESSURE HOSE INSTALLATION

- (1) Connect the pressure hose so that its notch part contacts the suction connector.

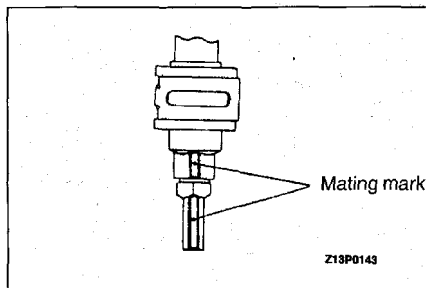

- (2) Align the marks on the pressure hose and pressure pipe, and install the pressure hose.

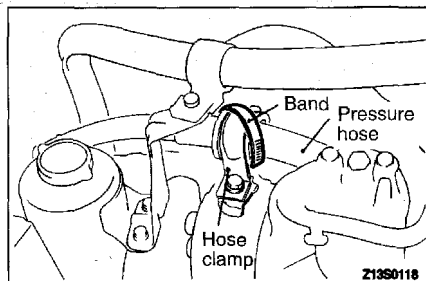

- (3) Install the band securely so that there is no play between the pressure hose and the hose clamp.
- (4) Confirm that there is a space of more than 10 mm (.39 in.) between the pressure hose and the brake pipe.

NOTE

Steps (3) and (4) are applicable only to the vehicles in which the band was being installed before servicing. For other vehicles, installation of a band is not required.