SERVICE BRAKES

CONTENTS

3510900012

BASIC BRAKE SYSTEM	35A
ANTI-LOCK BRAKING SYSTEM (ABS) <FWD>	35B

BASIC BRAKE SYSTEM

CONTENTS

35109000173

BRAKE PEDAL	18	Front Brake Disc Run-out Check	15
FRONT DISC BRAKE	22	Front Brake Disc Run-out Correction	15
GENERAL INFORMATION	3	Front Brake Disc Thickness Check	14
LUBRICANTS	4	Front Disc Brake Pad Check and Replacement	12
MASTER CYLINDER AND BRAKE BOOSTER	19	Front Disc Brake Rotor Check	14
Master Cylinder	21	Proportioning Valve Function Test	10
ON-VEHICLE SERVICE	8	Stop Light Switch Check	9
Bleeding	11	PROPORTIONING VALVE	32
Brake Booster Operating Test	9	REAR DRUM BRAKE	29
Brake Drum Inside Diameter Check	16	Wheel Cylinder	31
Brake Fluid Level Sensor Check	11	SEALANT	5
Brake Lining and Brake Drum Contact Check	17	SERVICE SPECIFICATIONS	4
Brake Lining Thickness Check	16	SPECIAL TOOLS	5
Brake Pedal Check and Adjustment	8	TROUBLESHOOTING	5
Check Valve Operation Check	10		

GENERAL INFORMATION

The brake system offers high dependability and durability along with improved braking performance and brake sensitivity.

- A tandem type master cylinder is equipped on all models.
- A single type brake booster have been adopted.

- Floating caliper, 1-piston, ventilated disc brakes have been adopted as the front brakes for all models.
- Each rear drum brake is equipped with leading-trailing type brake shoes.

Items		Specification	
Master cylinder	I.D. mm (in.)	22.22 (.87)	
Brake booster	Effective dia. of power cylinder mm (in.)	230 (9.1)	
	Boosting ratio	5.0	
Proportioning valve	Decompression ratio	0.25	
Front brakes	Disc effective dia. × thickness mm (in.)	Vehicles with 13 inch disc brake	184 × 18 (7.2 × .71)
		Vehicles with 14 inch disc brake	204 × 24 (8.0 × .94)
	Wheel cylinder I.D. mm (in.)	54.0 (2.13)	
	Pad thickness mm (in.)	10.0 (.39)	
Rear drum brakes	Drum I.D. mm (in.)	203 (8.0)	
	Wheel cylinder I.D mm (in.)	19.05 (.750)	
	Lining thickness mm (in.)	4.38 (.172)	

CONSTRUCTION DIAGRAM

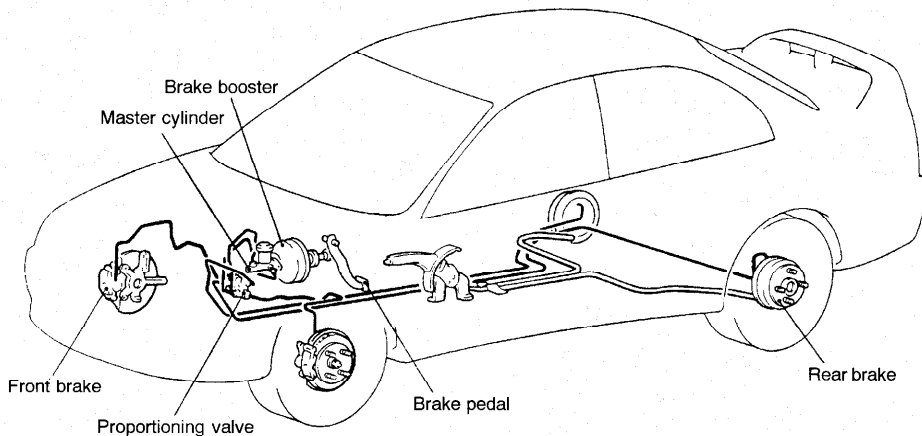

SERVICE SPECIFICATIONS

35100030317

Items		Standard value	Limit	
Brake pedal height mm (in.)		163.5 - 166.5 (6.44 - 6.56)	-	
Brake pedal free play mm (in.)		3 - 8 (.12 - .31)	-	
Brake pedal to floor board clearance mm (in.)		80 (3.15) or more	-	
Proportioning valve	Split point MPa (psi)	2-door models	2.45 ± 0.25 (356 ± 36)	-
		4-door models	2.94 ± 0.25 (427 ± 36)	-
	Output fluid pressure [Input fluid pressure] MPa (psi)	2-door models	4.30 ± 0.39 (623 ± 57) [9.81 (1422)]	-
		4-door models	4.66 ± 0.39 (676 ± 57) [9.81 (1422)]	-
Left/right proportioning valve output pressure difference MPa (psi)		-	0.39 (56.9)	
Front disc brake	Pad thickness mm (in.)		10.0 (.39)	2.0 (.08)
Rear drum brake	Disc thickness mm (in.)	Vehicles with 13 inch disc brake	18.0 (.71)	16.4 (.65)
		Vehicles with 14 inch disc brake	24.0 (.94)	22.4 (.88)
Disc runout mm (in.)		-	0.06 (.0024)	
Drag force (tangential force of wheel mounting bolts) N (lbs.)	Vehicles with 13 inch disc brake	59 (13) or less	-	
	Vehicles with 14 inch disc brake	94 (21) or less	-	
Lining thickness mm (in.)		4.38 (.172)	1.00 (.039)	
Drum inside diameter mm (in.)		203 (8.0)	205 (8.1)	
Front hub end play mm (in.)		-	0.05 (.0020)	

LUBRICANTS

35100040099

Items	Specified lubricant
Brake fluid	DOT3 or DOT4
Brake piston seal	Repair kit grease (orange)
Slide pin boot and slide pin bush inner surfaces	
Brake piston boot inner surfaces	
Piston boot mounting grooves	
Rear brake shoe and backing plate contact surface	
Shoe assembly and auto adjuster assembly contact surfaces	
Shoe and lever assembly and auto adjuster assembly contact surfaces	

SEALANT

35100050092

Items	Specified sealant	Remarks
Intake manifold thread	3M ATD Part No. 8661 or equivalent	Semi-drying sealant

SPECIAL TOOLS

35100060088

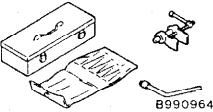
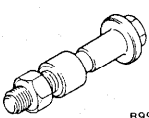
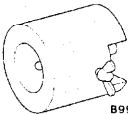
Tool	Tool number and name	Supersession	Application
	MB990964 MB990520 MB990619 Brake tool set	General service tool	<ul style="list-style-type: none"> Pushing-in of the disc brake piston Installation of drum brake wheel cylinder piston cup
	MB990998 Front hub remover and installer	MB990998-01	Provisional holding of the wheel bearing
	MB991714 Push rod adjusting gauge	-	Clearance adjustment between the brake booster push rod and primary piston

TROUBLESHOOTING

35100070029

Symptom	Probable cause	Remedy
Vehicle pulls to one side when brakes are applied	Grease or oil on pad or lining surface	Replace
	Inadequate contact of pad or lining	Correct
	Auto adjuster malfunction	Adjust
	Drum out of round or uneven wear	Repair or replace as necessary
	Caliper piston sticking	Repair
Insufficient braking power	Low or deteriorated brake fluid	Refill or change
	Air in brake system	Bleed air from system
	Overheated brake rotor due to dragging of pad or lining	Correct
	Inadequate contact of pad or lining	
	Brake booster malfunction	
	Clogged brake line	
	Grease or oil on pad or lining surface	Replace
	Proportioning valve malfunction	Adjust
Auto adjuster malfunction		

Symptom	Probable cause	Remedy
Increased pedal stroke (Reduced pedal to floorboard clearance)	Air in brake system	Bleed air from system
	Worn lining or pad	Replace
	Broken vacuum hose	
	Faulty master cylinder	
	Brake fluid leaks	Correct
	Auto adjuster malfunction	Adjust
	Excessive push rod to master cylinder clearance	
Brake drag	Incomplete release of parking brake	Correct
	Clogged master cylinder return port	
	Incorrect parking brake adjustment	Adjust
	Incorrect push rod to master cylinder clearance	
	Faulty master cylinder piston return spring	Replace
	Worn brake pedal return spring	
	Broken rear drum brake shoe return spring	
	Caliper piston sticking	Repair
Lack of lubrication in sliding parts	Lubricate	
Scraping or grinding noise when brakes are applied	Worn brake lining or pad	Replace
	Caliper to wheel interference	Correct or replace
	Dust cover to disc interference	
	Bent brake backing plate	
	Cracked drums or brake disc	
Squealing, groaning or chattering noise when brakes are applied	Missing or damaged brake pad anti-squeak shim	Replace
	Brake drums and linings, discs and pads worn or scored	Correct or replace
	Incorrect parts	
	Burred or rusted calipers	Clean or deburr
	Dirty, greased, contaminated or glazed linings	Clean or replace
	Drum brakes-weak, damaged or incorrect shoe hold-down springs, loose or damaged shoe hold-down pins and springs	Correct or replace
	Incorrect brake pedal or booster push rod setting	Adjust

Symptom	Probable cause	Remedy
Squealing noise when brakes are not applied	Bent or warped backing plate causing interference with drum	Replace
	Drum brakes-weak, damaged or incorrect shoe-to-shoe spring	
	Poor return of brake booster, master cylinder or wheel cylinder	
	Loose or excessive brake parts	Retighten
	Improper positioning of pads in caliper	Correct
	Improper installation of support mounting to caliper body	
	Improper machining of drum causing interference with backing plate or shoe	Replace drum
	Disc brakes-rusted, stuck	Lubricate or replace
	Worn, damaged or insufficiently lubricated wheel bearings	
Incorrect brake pedal or booster push rod setting	Adjust	
Groaning clicking or rattling noise when brakes are not applied	Stones or foreign material trapped inside wheel covers or drums	Remove stones, etc.
	Loose wheel nuts	Retighten
	Disc brakes-loose installation bolt	
	Worn, damaged or dry wheel bearings	Lubricate or replace
	Disc brakes-failure of anti-rattle shim	Replace
	Disc brakes-wear on sleeve	
Incorrect brake pedal or booster push rod setting	Adjust	

ON-VEHICLE SERVICE

BRAKE PEDAL CHECK AND ADJUSTMENT

1. Turn up the carpet, etc. under the brake pedal.
2. Measure the brake pedal height as illustrated. If the brake pedal height is not within the standard value, follow the procedure below.

Standard value: 163.5 - 166.5 mm (6.44 - 6.56 in.)

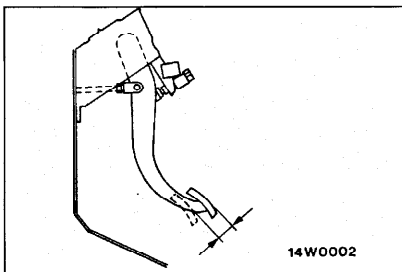
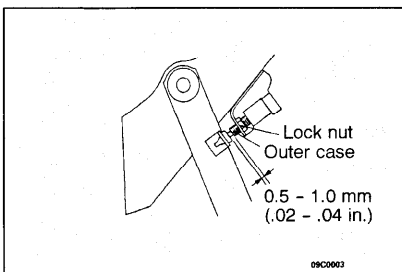
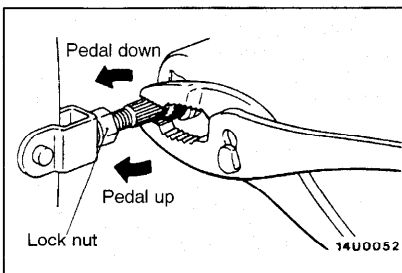
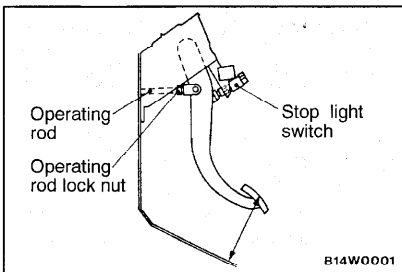

- (1) Disconnect the stop light switch connector.
- (2) Adjust the brake pedal height by turning the operating rod with pliers (with the operating rod lock nut loosened), until the correct brake pedal height is obtained.
- (3) Secure by tightening the lock nut of the operating rod.
- (4) Push the stop light switch in the direction of the pedal stroke until it stops. (The switch will slide if it is pushed firmly.)
- (5) Lift up the pedal until the operating rod is fully extended, and then slide the stop light switch back to the required position. Adjust the position of the switch by turning it until the distance shown in the illustration is correct.
- (6) Connect the connector of the stop light switch.
- (7) Check that the stop light is not illuminated with the brake pedal unpressed.

3. With the engine stopped, depress the brake pedal two or three times. After eliminating the vacuum in the power brake booster, press the pedal down by hand, and confirm that the amount of movement before resistance is met (the free play) is within the standard value range.

Standard value: 3 - 8 mm (.12 - .31 in.)

If the free play exceeds the standard value, it is probably due to excessive play between the retaining ring bolt and brake pedal arm.

Check for excessive clearance and replace faulty parts as required.

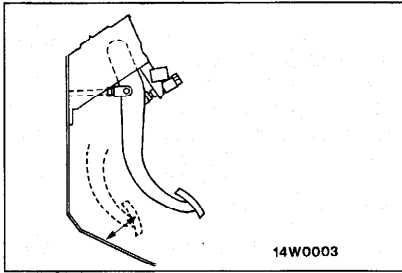

4. Start the engine, depress the brake pedal with approximately 490 N (110 lbs.) of force, and measure the clearance between the brake pedal and the floorboard.

Standard value: 80 mm (3.15 in.) or more

If the clearance is outside the standard value, check for air trapped in the brake line, clearance between the lining and the drum and dragging in the parking brake. Adjust and replace defective parts as required.

5. Turn back the carpet to its original position.

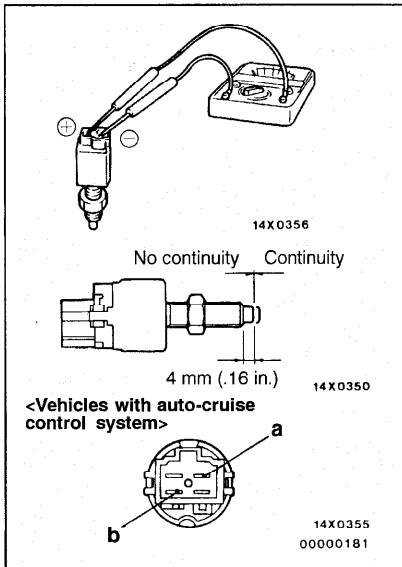

STOP LIGHT SWITCH CHECK

Connect an ohmmeter to the stop light switch, and check whether or not there is continuity when the plunger of the stop light switch is pushed in and when it is released. The stop light switch is in good condition if there is no continuity when the plunger is pushed in to a depth of within 4 mm (.16 in.) from the outer case edge surface, and if there is continuity when it is released.

For vehicles with auto-cruise control system, the check for continuity should be made at connectors "a" and "b" of the stop light switch.

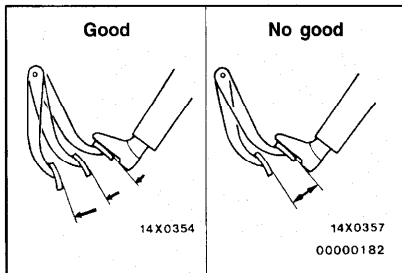

BRAKE BOOSTER OPERATING TEST

35100100049

For simple checking of the brake booster operation, carry out the following tests:

1. Run the engine for one or two minutes, and then stop it.

If the pedal depresses fully the first time but gradually becomes higher when depressed succeeding times, the booster is operating properly, if the pedal height remains unchanged, the booster is defective.

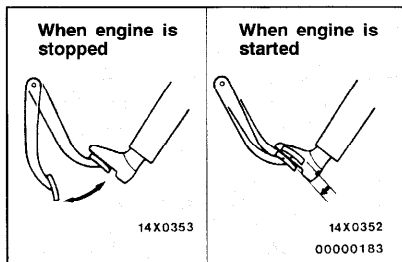

2. With the engine stopped, step on the brake pedal several times.

Then step on the brake pedal and start the engine. If the pedal moves downward slightly, the booster is in good condition. If there is no change, the booster is defective.

- With the engine running, step on the brake pedal and then stop the engine.
Hold the pedal depressed for 30 seconds. If the pedal height does not change, the booster is in good condition, if the pedal rises, the booster is defective.
If the above three tests are okay, the booster performance can be determined as good.
If one of the above three tests is not okay at last, the check valve, vacuum hose, or booster will be defective.

CHECK VALVE OPERATION CHECK

35100900106

- Remove the vacuum hose. (Refer to P.35A-18.)

Caution

The check valve should not be removed from the vacuum hose.

- Check the operation of the check valve by using a vacuum pump.

Vacuum pump connection	Accept/reject criteria
Connection at the brake booster side (A)	A negative pressure (vacuum) is created and held.
Connection at the intake manifold side (B)	A negative pressure (vacuum) is not created.

Caution

If the check valve is defective, replace it as an assembly unit together with the vacuum hose.

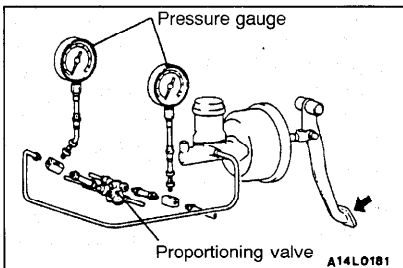
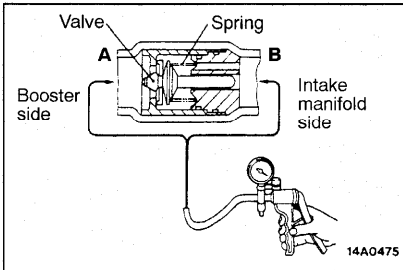

PROPORTIONING VALVE FUNCTION TEST

35100110097

- Connect two pressure gauges, one each to the input side and output side of the proportioning valve, as shown.
- Bleed the air in the brake line and the pressure gauge.
- While gradually depressing the brake pedal, make the following measurements and check to be sure that the measured values are within the allowable range.

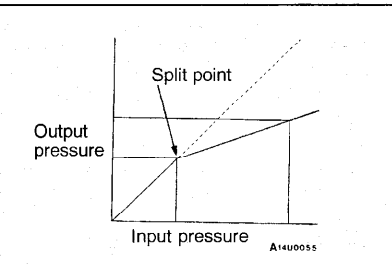

- (1) Output pressure begins to drop relative to input pressure (split point).

Standard value:

MPa (psi)

2-door models	4-door models
2.45 ± 0.25 (356 ± 36)	2.94 ± 0.25 (427 ± 36)

- (2) Check to be sure that the output fluid pressure is at the standard value when the pedal depression force is increased so that the input fluid pressure is 9.81 MPa (1422 psi).

Standard value:

MPa (psi)

2-door models	4-door models
4.30 ± 0.39 (623 ± 57)	4.66 ± 0.39 (676 ± 57)

- (3) Output pressure difference between left and right brake lines.

Limit: 0.39 MPa (56.9 psi)

4. If the measured pressures are not within the permissible ranges, replace the proportioning valve.

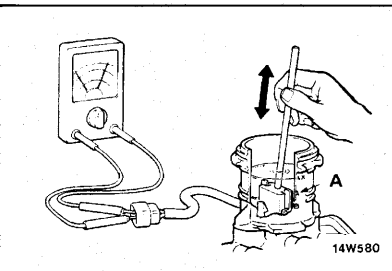

BRAKE FLUID LEVEL SENSOR CHECK 35100910086

The brake fluid level sensor is in good condition if there is no continuity when the float surface is above "A" and if there is continuity when the float surface is below "A."

BLEEDING

35100140096

Caution

Use the specified brake fluid. Avoid using a mixture of the specified brake fluid and other fluid.

Specified brake fluid: DOT3 or DOT4

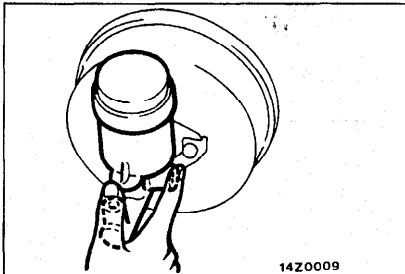

MASTER CYLINDER BLEEDING

The master cylinder used has no check valve, so if bleeding is carried out by the following procedure, bleeding of air from the brake pipeline will become easier. (When brake fluid is not contained in the master cylinder.)

- (1) Fill the reserve tank with brake fluid.
- (2) Keep the brake pedal depressed.
- (3) Have another person cover the master cylinder outlet with a finger.
- (4) With the outlet still closed, release the brake pedal.
- (5) Repeat steps (2)-(4) three or four times to fill the inside of the master cylinder with brake fluid.

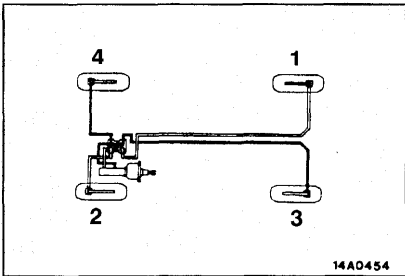

BRAKE PIPE LINE BLEEDING

Bleed the air in the sequence shown in the figure.

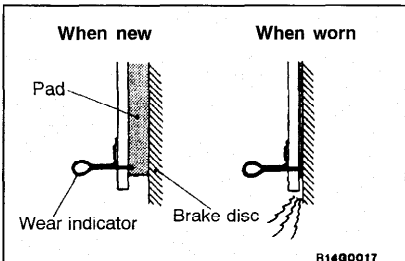

FRONT DISC BRAKE PAD CHECK AND REPLACEMENT

35100150211

NOTE

The left side inner brake pad has a wear indicator. The wear indicator contacts the brake disc when the brake pad thickness becomes 2 mm (.08 in.) and emit a squealing sound to warn the driver.

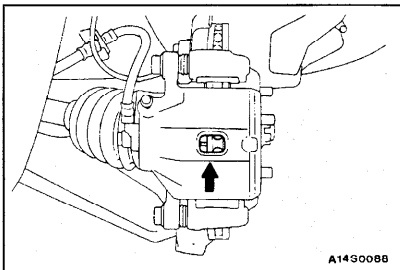

1. Check brake pad thickness through caliper body check port.

Standard value: 10 mm (.39 in.)

Limit: 2.0 mm (.08 in.)

Caution

1. When the limit is exceeded, replace the pads at both sides, and also the brake pads for the wheels on the opposite side at the same time.
2. If there is a significant difference in the thickness of the pads on the left and right sides, check the sliding condition of the piston, lock pin and guide pin.

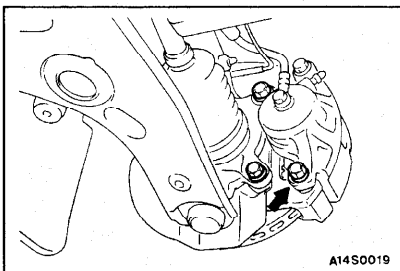

2. Remove the slide pin (M14) or guide pin. Lift caliper assembly and retain with wires.

Caution

Do not wipe off the special grease that is on the slide pin/guide pin or allow it to contaminate the slide pin/guide pin.

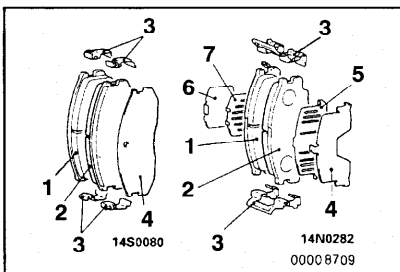

3. Remove the following parts from caliper support.
 1. Pad and wear indicator assembly <L.H.>, and pad assembly <R.H.>
 2. Pad assembly
 3. Pad clip
 4. Outer shim
 5. Outer shim
 6. Inner shim
 7. Inner shim

4. In order to measure the brake drag force after pad installation, measure the rotary-sliding resistance of the hub with the pads removed. (Refer to P.35A-22.)
5. Install the pads and the caliper assembly, and then check the brake drag force. (Refer to P.35A-22.)

FRONT DISC BRAKE ROTOR CHECK

35100270061

CAUTION

When servicing disc brakes, it is necessary to exercise caution to keep the disc brakes within the allowable service values in order to maintain normal brake operation.

Before re-finishing or re-processing the brake disc surface, the following conditions should be checked.

Inspection items	Remarks
Scratches, rust, saturated lining materials and wear	<ul style="list-style-type: none"> If the vehicle is not driven for a certain period, the sections of the discs that are not in contact with lining will become rusty, causing noise and shuddering. If grooves resulting from excessive disc wear and scratches are not removed prior to installing a new pad assembly, there will momentarily be inappropriate contact between the disc and the lining (pad).
Run-out or drift	Excessive run-out or drift of the discs will increase the pedal depression resistance due to piston knock-back.
Change in thickness (parallelism)	If the thickness of the disc changes, this will cause pedal pulsation, shuddering and surging.
Inset or warping (flatness)	Overheating and improper handling while servicing will cause inset or warping.

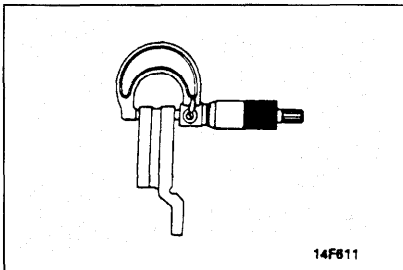

FRONT BRAKE DISC THICKNESS CHECK

35100160214

- Using a micrometer, measure disc thickness at eight positions, approximately 45° apart and 10 mm (.39 in.) in from the outer edge of the disc.

Brake disc thickness

Standard value:

18.0 mm (.71 in.) <Vehicles with 13 inch front disc brake>

24.0 mm (.94 in.) <Vehicles with 14 inch front disc brake>

Minimum limit:

16.4 mm (.65 in.) <Vehicles with 13 inch front disc brake>

22.4 mm (.88 in.) <Vehicles with 14 inch front disc brake>

Thickness variation (at least 8 positions)

The difference between any thickness measurements should not be more than 0.015 mm (.0006 in.).

- If the disc is beyond the limits for thickness, remove it and install a new one. If thickness variation exceeds the specification, replace the brake disc or turn rotor with on the car type brake lathe ("Accuturn-8750" or equivalent).

FRONT BRAKE DISC RUN-OUT CHECK

35100170095

- Remove the caliper support; then raise the caliper assembly upward and secure with a wire.
- Inspect the disc surface for grooves, cracks and rust. Clean the disc thoroughly and remove all rust.

- Place a dial gauge approximately 5 mm (.2 in.) from the outer circumference of the brake disc, and measure the run-out of the disc.

Limit: 0.06 mm (.0024 in.) or less

NOTE

Tighten the nuts in order to secure the disc to the hub.

FRONT BRAKE DISC RUN-OUT CORRECTION

35100180098

- If the run-out of the brake disc is equivalent to or exceeds the limit specification, change the phase of the disc and hub, and then measure the run-out again.
 - Before removing the brake disc, chalk both sides of the wheel stud on the side at which run-out is greatest.

- Remove the brake disc, and then place a dial gauge as shown in the illustration; then move the hub in the axial direction and measure the play.

Limit: 0.05 mm (.0020 in.)

If the play is equivalent to or exceeds the limit, disassemble the hub knuckle and check each part.

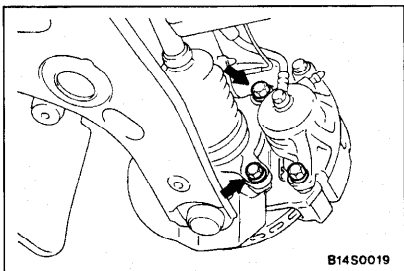

B14S0019

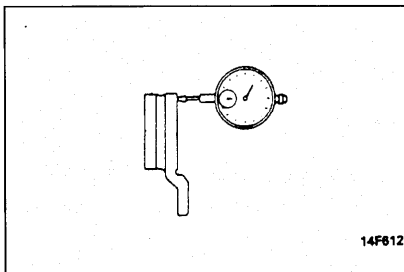

14F812

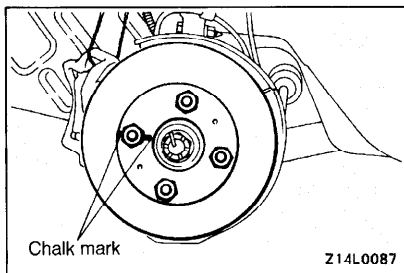

Chalk mark

Z14L0087

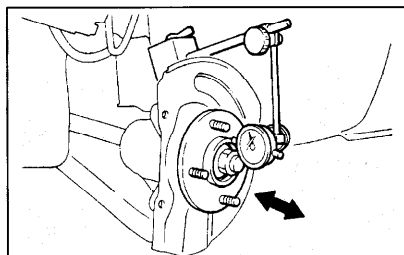

A11C0017

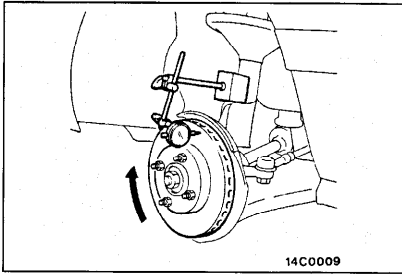

- (3) If the play does not exceed the limit specification, install the brake disc at a position 180° away from the chalk mark, and then check the run-out of the brake disc once again.

2. If the run-out cannot be corrected by changing the phase of the brake disc, replace the disc or turn rotor with on the car type brake lathe ("Accuturn-8750" or equivalent).

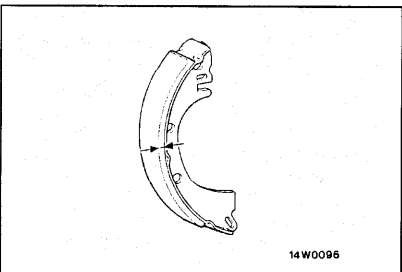

BRAKE LINING THICKNESS CHECK

35100300111

1. Remove the brake drum.
2. Measure the wear of the brake lining at the place worn the most.

Standard value: 4.38 mm (.172 in.)

Limit: 1.00 mm (.039 in.)

Replace the shoe and lining assembly if brake lining thickness is less than the limit or if it is not worn evenly. For information concerning the procedures for installation of the shoe and lining assembly, refer to P.35A-26.

Caution

1. Whenever the shoe and lining assembly is replaced, replace both RH and LH assemblies as a set to prevent the car from pulling to one side when braking.
2. If there is a significant difference in the thickness of the shoe and lining assemblies on the left and right sides, check the sliding condition of the piston.

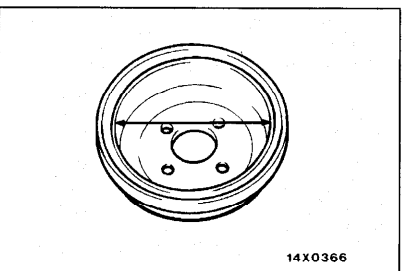

BRAKE DRUM INSIDE DIAMETER CHECK

35100320100

1. Remove the brake drum.
2. Measure the inside diameter of the brake drum at two or more locations.

Standard value: 203 mm (8.0 in.)

Limit: 205 mm (8.1 in.)

3. Replace brake drums, shoe and lining assembly when wear exceeds the limit value or is badly imbalanced.

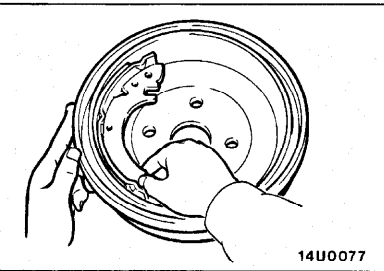

BRAKE LINING AND BRAKE DRUM CONTACT CHECK

35100310114

1. Remove the brake drum.
2. Remove the shoe and lining assembly.
(Refer to P.35A-29.)
3. Chalk inner surface of brake drum and rub with shoe and lining assembly.
4. Replace shoe and lining assembly or brake drums if there are any irregular contact area.

NOTE

Clean off chalk after check.

BRAKE PEDAL

REMOVAL AND INSTALLATION

Pre-removal Operation

- Knee Protector Assembly Removal (Refer to GROUP 52A – Instrument Panel.)
- Steering Column Assembly Removal (Refer to GROUP 37A – Steering Wheel and Shaft.)
- Accelerator Pedal Removal (Refer to GROUP 17.)

Post-installation Operation

- Accelerator Pedal Installation (Refer to GROUP 17.)
- Steering Column Assembly Installation (Refer to GROUP 37A – Steering Wheel and Shaft.)
- Knee Protector Assembly Installation (Refer to GROUP 52A – Instrument Panel.)
- Brake Pedal Adjustment (Refer to P.35A-8.)

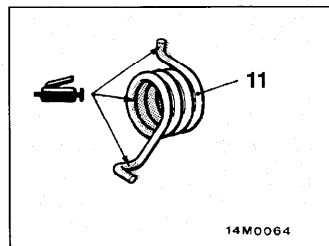
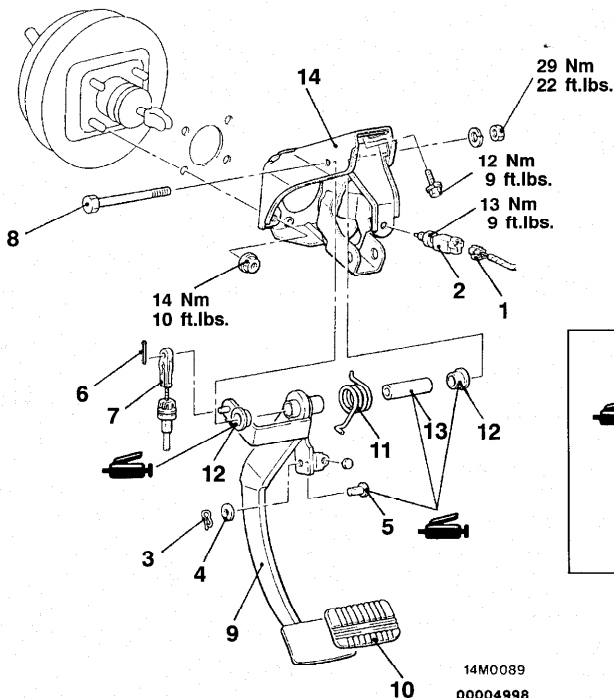

14M0089
00004998

Removal steps

1. Stop light switch connector
2. Stop light switch
3. Snap pin
4. Washer
5. Clevis pin
6. Cotter pin <A/T>
7. Shift lock cable connection <A/T>
8. Brake pedal shaft bolt
9. Brake pedal
10. Brake pedal pad
11. Brake pedal return spring
12. Bushing
13. Pipe
14. Pedal support member

MASTER CYLINDER AND BRAKE BOOSTER

REMOVAL AND INSTALLATION

Pre-removal Operation

- Brake Fluid Draining
- Air Intake Hose Removal

Post-installation Operation

- Brake Fluid Supplying
- Brake Line Bleeding (Refer to P.35A-11.)
- Brake Pedal Adjustment (Refer to P.35A-8.)
- Air Intake Hose Installation

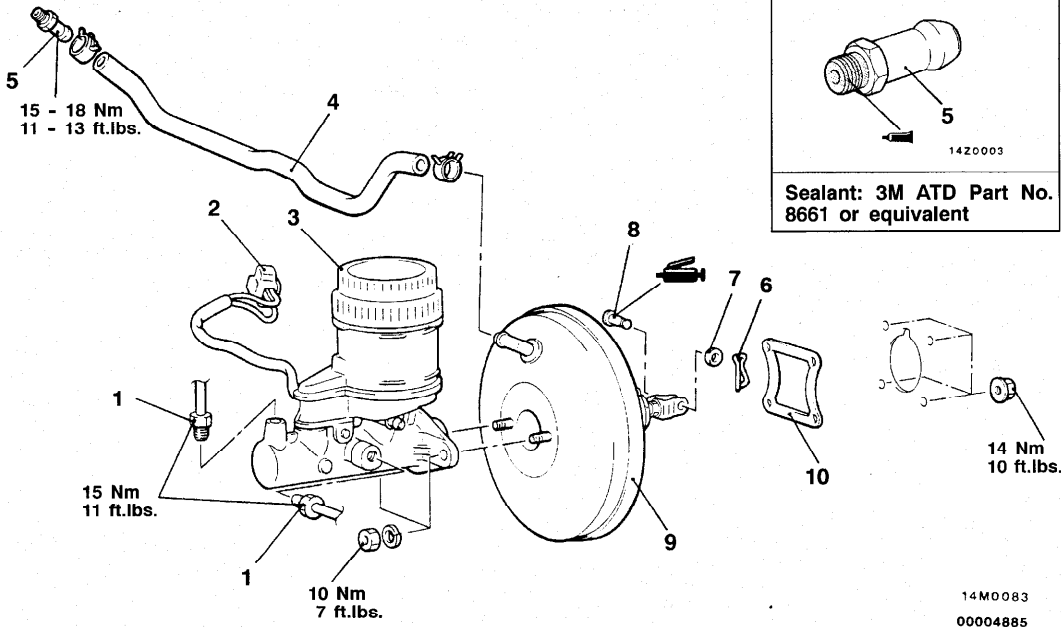

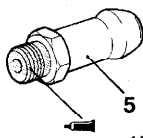
 1420003

Sealant: 3M ATD Part No. 8661 or equivalent

Removal steps

1. Brake pipe connection
 2. Brake fluid level sensor connector
 3. Master cylinder assembly
 - Clearance adjustment between brake booster push rod and primary piston
- B◄
- A◄

5. Fitting
6. Snap pin
7. Washer
8. Clevis pin
9. Brake booster
10. Sealer

INSTALLATION SERVICE POINTS

►A◄ VACUUM HOSE CONNECTION

Insert securely and completely until the vacuum hose at the engine side contacts the edge of the hexagonal part of the fitting, and then secure by using the hose clip.

►B◄ CLEARANCE ADJUSTMENT BETWEEN BRAKE BOOSTER PUSH ROD AND PRIMARY PISTON

1. Set the special tool in the master cylinder.
2. Set the special tool shaft to a position where it lightly contacts the master cylinder piston.
3. Turn the wing bolt to fix the shaft.
4. Using a hand vacuum pump, apply a vacuum of -66.7 kPa (19.6 in.Hg) to the brake booster.
5. Reverse the special tool to shift it from the center of the brake booster.

6. Slide the special tool toward the center, and confirm that the protrusion of the shaft contacts the end of the brake booster push rod as shown in drawing A on the left. If the state is as shown in drawings B and C on the left, adjust the push rod length with the following steps to achieve the state shown in A.
 - B: If a section other than the shaft protrusion is contacted, shorten the push rod.
 - C: If there is no contact with the shaft, extend the push rod.

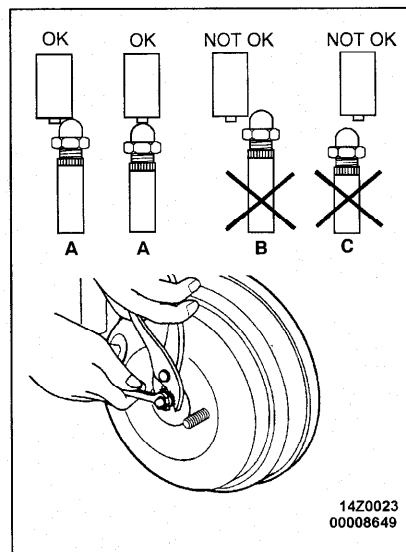
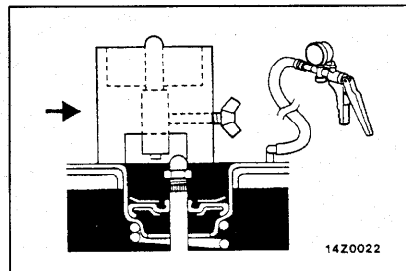
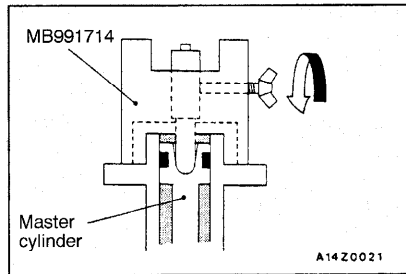

**MASTER CYLINDER
DISASSEMBLY AND REASSEMBLY**

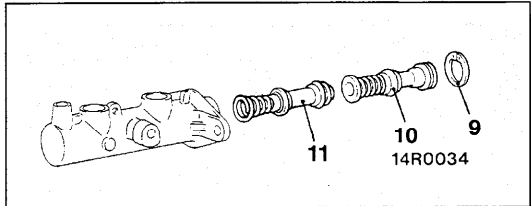
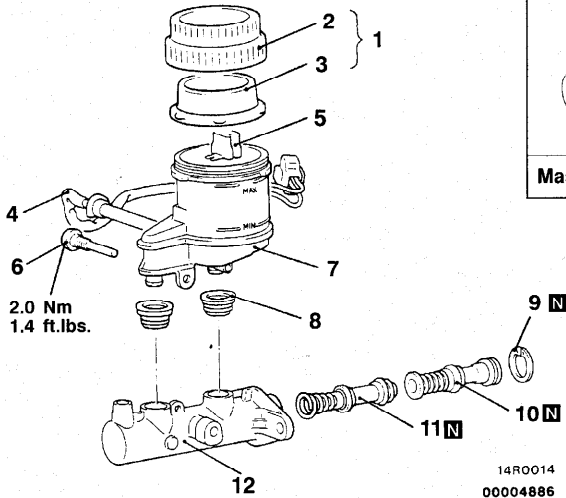

Master cylinder kit

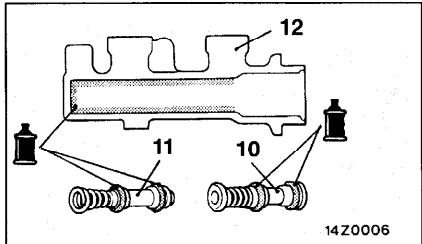

Brake fluid: DOT3 or DOT4

Disassembly steps

1. Reservoir cap assembly
2. Reservoir cap
3. Diaphragm
4. Brake fluid level sensor
5. Float
6. Reservoir stopper bolt



7. Reservoir tank
8. Reservoir seal
9. Piston stopper ring
10. Primary piston assembly
11. Secondary piston assembly
12. Master cylinder body

DISASSEMBLY SERVICE POINT

◀A▶ PISTON STOPPER RING DISASSEMBLY

Remove the piston stopper ring, while depressing the piston.



FRONT DISC BRAKE

REMOVAL AND INSTALLATION

Pre-removal Operation

- Brake Fluid Draining

Post-installation Operation

- Brake Fluid Supplying
- Brake Line Bleeding (Refer to P.35A-11.)

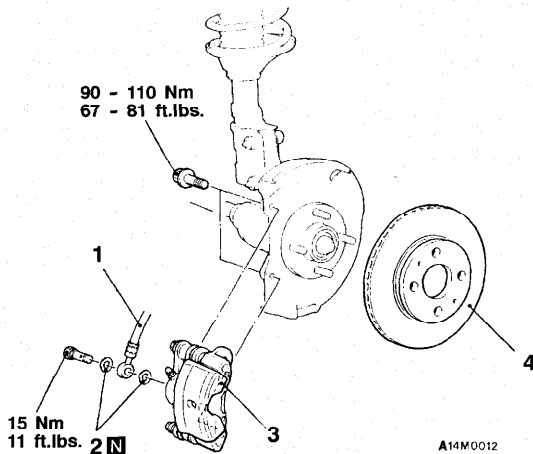
**Removal steps**

1. Brake hose connection
2. Gasket
3. Disc brake assembly
4. Brake disc

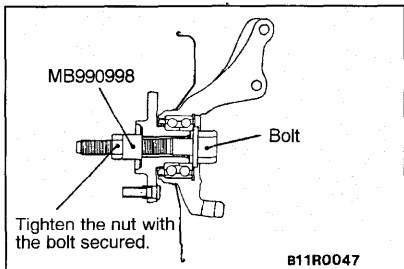
**INSTALLATION SERVICE POINT****►A◄ DISC BRAKE ASSEMBLY INSTALLATION**

1. In order to measure the brake drag force after pad installation, measure the rotary-sliding resistance of the hub by the following procedure with the pads removed.
 - (1) Remove the drive shaft.
(Refer to GROUP 26 – Front Axle.)
 - (2) Attach the special tool to the front hub assembly as shown in the illustration, and tighten it to the specified torque.

Tightening torque: 177 - 275 Nm (130 - 203 ft.lbs.)

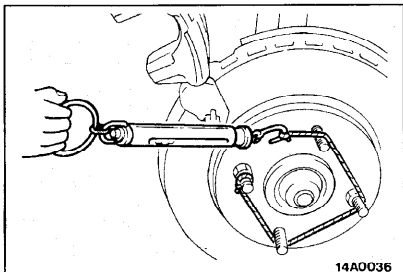

14A0036

- (3) Use a spring scale to measure the rotary-sliding resistance of the hub in the forward direction.

2. After installing the caliper support to the knuckle, install the pad clips and the pads to the caliper support.

Caution

Do not let any oil, grease or other contamination get onto the friction surfaces of the pads and brake discs.

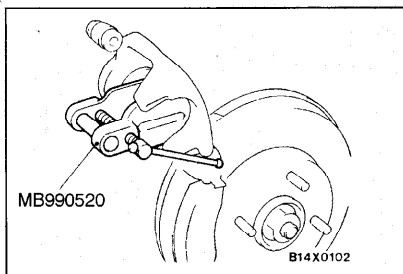

MB990520

B14X0102

3. Clean piston and insert into cylinder with special tool.
4. Be careful that the piston boot does not become caught when lowering the caliper assembly, and tighten the slide pin (M14) to the specified torque.

Tightening torque: 83 - 93 Nm (61 - 69 ft.lbs.)

5. Start the engine and then depress the brake pedal 2-3 times.
6. Stop engine.
7. Turn brake disc forward 10 times.

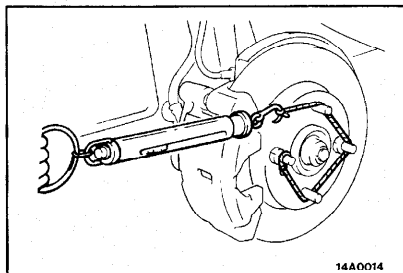

14A0014

8. Use a spring scale to measure the rotation sliding resistance of the hub in the forward direction.
9. Calculate the drag force of the disc brake (difference between of values measured in item 8 and item 1.)

Standard value:

59 N (13 lbs.) or less <Vehicles with 13 inch front disc brake>

94 N (21 lbs.) or less <Vehicles with 14 inch front disc brake>

10. If the drag force of the disc brake exceeds the standard value, disassemble piston and clean piston. Check for corrosion or worn piston seal, and check the sliding condition of the slide pins.

DISASSEMBLY AND REASSEMBLY

<13 inch front disc brake>

35100620286

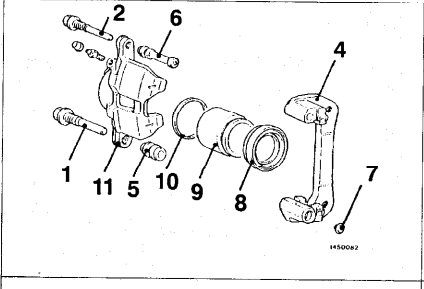
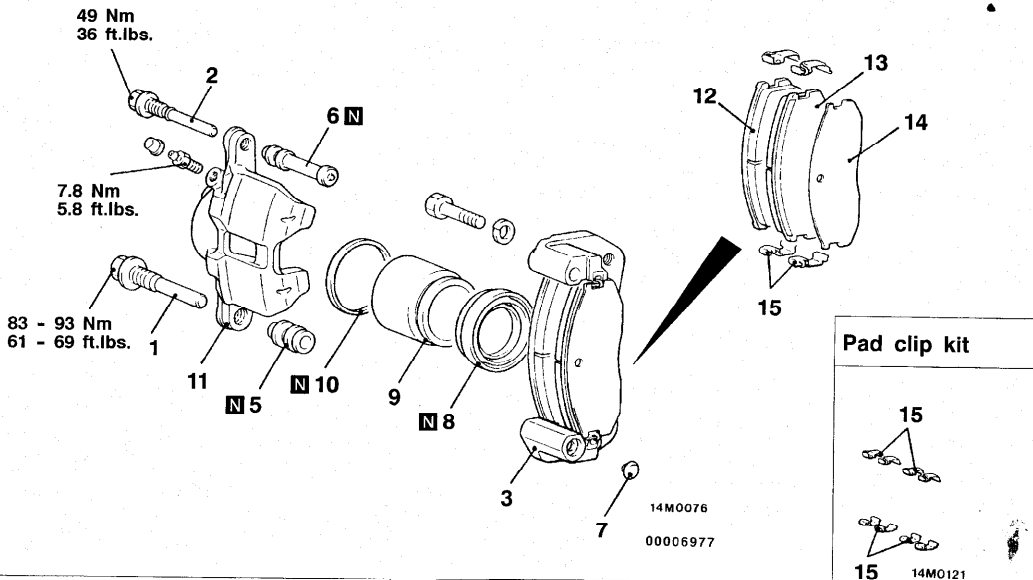

Brake caliper kit

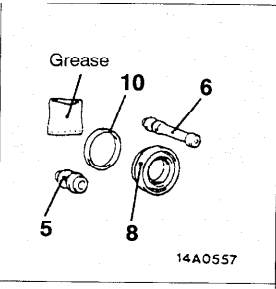

Seal and boots repair kit

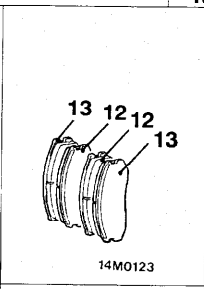

Pad set

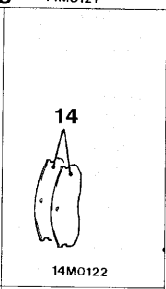

Shim kit

Caliper assembly disassembly steps

1. Slide pin (M14)
2. Slide pin (M10)
3. Torque member, pad, pad clip, shim assembly
4. Torque member
5. Boot
6. Bush
7. Plug
8. Piston boot
9. Piston
10. Piston seal
11. Caliper body

Pad assembly disassembly steps

1. Slide pin (M14)
2. Slide pin (M10)
3. Torque member, pad, pad liner, shim assembly
12. Pad and wear indicator assembly <L.H.> or pad assembly <R.H.>
13. Pad assembly
14. Outer shim (coated with rubber)
15. Pad clip



<14 inch front disc brake>

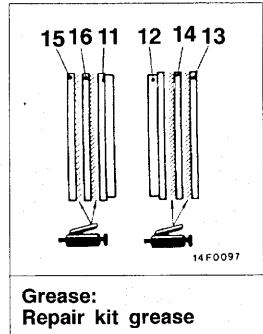
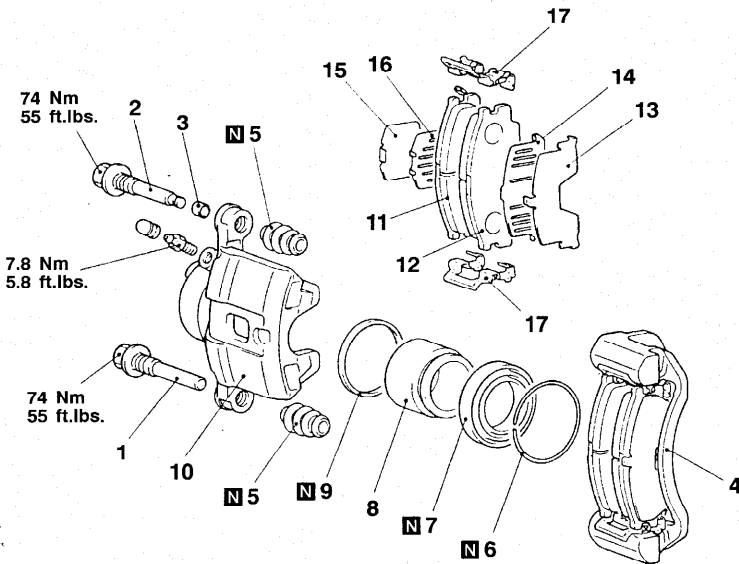

14N0282

00008714

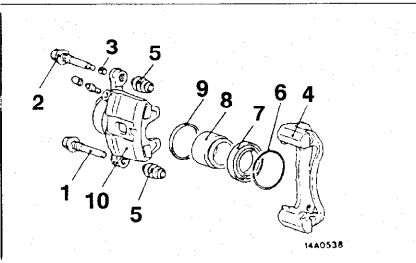

Brake caliper kit

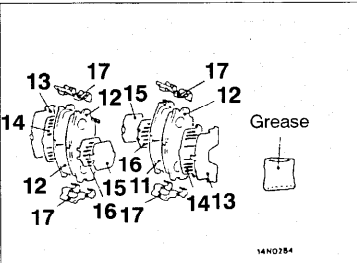

Pad kit

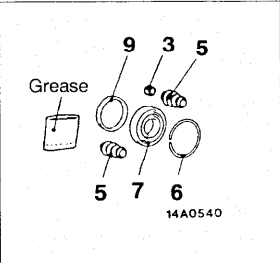

Seal and boots repair kit

Caliper assembly disassembly steps



1. Guide pin
2. Lock pin
3. Bush
4. Caliper support, pad, pad clip, shim assembly
5. Boot
6. Boot ring
7. Piston boot
8. Piston
9. Piston seal
10. Caliper body

Pad assembly disassembly steps



1. Guide pin
2. Lock pin
3. Bush
4. Caliper support, pad, pad clip, shim assembly
11. Pad and wear indicator assembly <L.H.> or pad assembly <R.H.>
12. Pad assembly
13. Outer shim
14. Outer shim
15. Inner shim
16. Inner shim
17. Pad clip



LUBRICATION POINTS

<13 inch front disc brake>

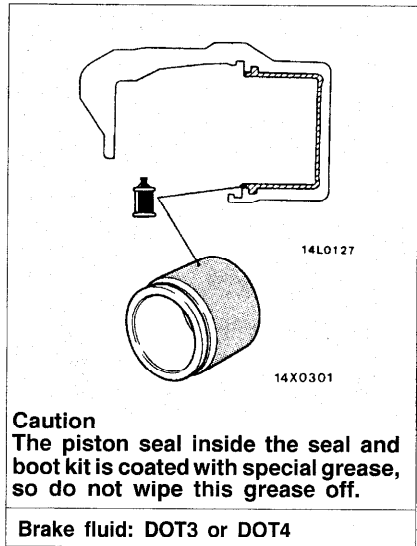

14L0127

14X0301

Caution
The piston seal inside the seal and boot kit is coated with special grease, so do not wipe this grease off.

Brake fluid: DOT3 or DOT4

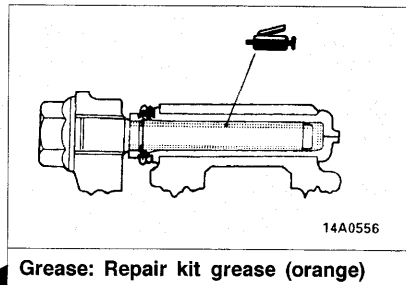

14A0556

Grease: Repair kit grease (orange)

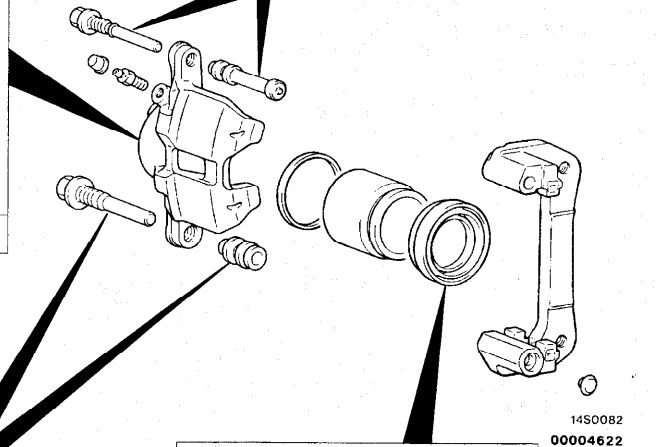

14S0082
00004622

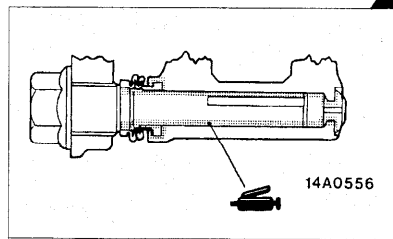

14A0556

Grease: Repair kit grease (orange)

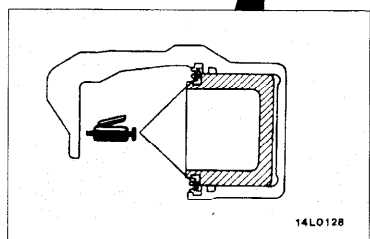

14L0128

Grease: Repair kit grease (orange)

<14 inch front disc brake>

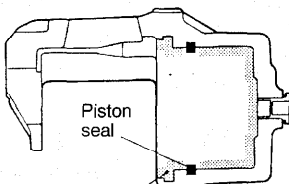

Piston seal

14X0302

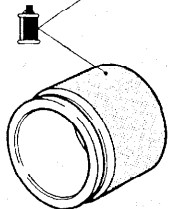

14X0301

Caution
The piston seal inside the seal and boot kit is coated with special grease, so do not wipe this grease off.

Brake fluid: DOT3 or DOT4

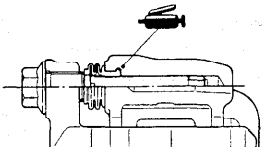

14W0046

Grease: Repair kit grease

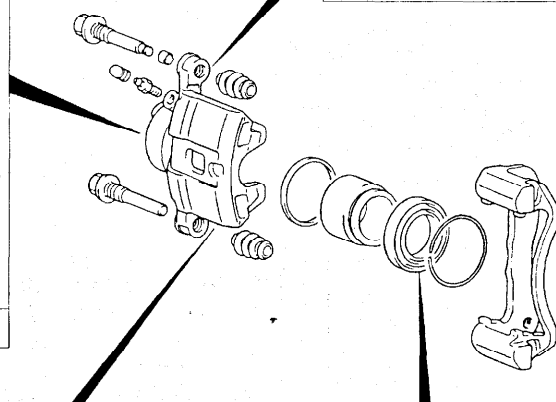

00008715
14A0538

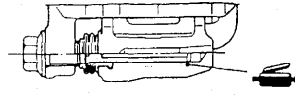

14A0541

Grease: Repair kit grease

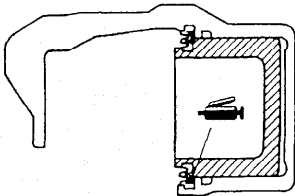

14L0128

Grease: Repair kit grease

DISASSEMBLY SERVICE POINTS

When disassembling the front disc brakes, disassemble both sides (left and right) as a set.

◀A▶ PISTON BOOT/PISTON REMOVAL

Protect caliper body with cloth. Blow compressed air through brake hose to remove piston boot and piston.

Caution

Blow compressed air gently and wear eye protection.

◀B▶ PISTON SEAL REMOVAL

- (1) Remove piston seal with finger tip.

Caution

Do not use a flat-tipped screwdriver or other tool to prevent damage to inner cylinder.

- (2) Clean piston surface and inner cylinder with trichloroethylene, alcohol or specified brake fluid.

Specified brake fluid: DOT3 or DOT4

REASSEMBLY SERVICE POINT**▶A◀ LOCK PIN/GUIDE PIN INSTALLATION**

Install the lock pin and guide pin so that the pin head marks correspond to the identification marks on the caliper body.

INSPECTION

- Check cylinder for wear, damage or rust.
- Check piston surface for wear, damage or rust.
- Check caliper body or sleeve for wear.
- Check pad for damage or adhesion of grease, check backing metal for damage.

35100630081

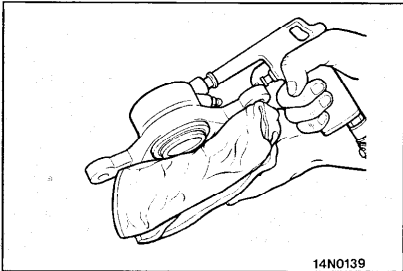

14N0139

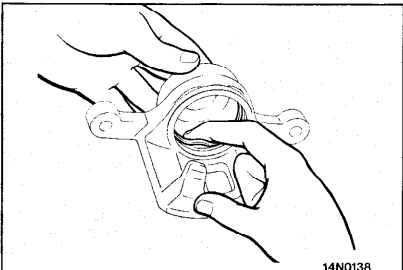

14N0138

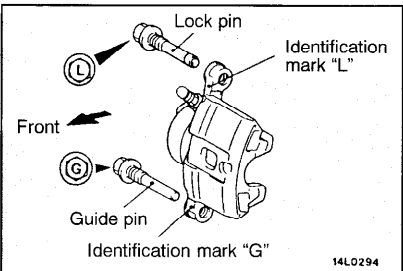

14L0294

REAR DRUM BRAKE

REMOVAL AND INSTALLATION

Pre-removal Operation

- Loosening the Parking Brake Cable Adjusting Nut.
- Brake Fluid Draining

Post-installation Operation

- Brake Line Bleeding (Refer to P.35A-11.)
- Parking Brake Lever Stroke Adjustment (Refer to GROUP 36 - On-vehicle Service.)

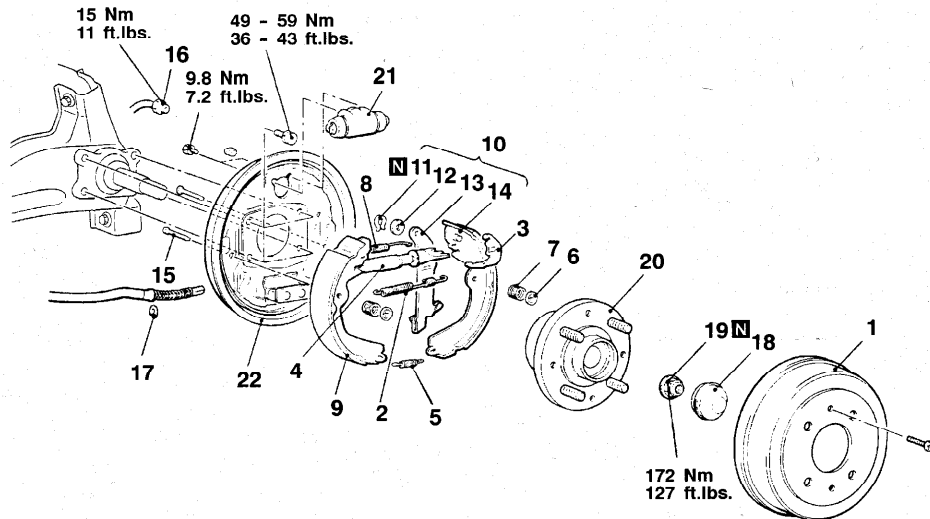

A14M0054

Rear drum brake removal steps

1. Brake drum
2. Shoe-to-lever spring
3. Adjuster lever
4. Auto adjuster assembly
5. Retainer spring
6. Shoe hold-down cup
7. Shoe hold-down spring
8. Shoe-to-shoe spring
9. Shoe and lining assembly
10. Shoe, lining and lever assembly
11. Retainer
12. Wave washer
13. Parking lever
14. Shoe and lining assembly
15. Shoe hold-down pin
16. Brake pipe connection
17. Snap ring
18. Hub cap

19. Flange nut
20. Rear hub assembly
21. Wheel cylinder
22. Backing plate

Wheel cylinder removal steps

1. Brake drum
2. Shoe-to-lever spring
8. Shoe-to-shoe spring
16. Brake pipe connection
21. Wheel cylinder

Caution

When removing the rear hub assembly, the wheel bearing inner race may be left at the spindle side. In this case, always replace the rear hub assembly, otherwise the hub will damage the oil seal, causing oil leaks or excessive play.

LUBRICATION POINTS

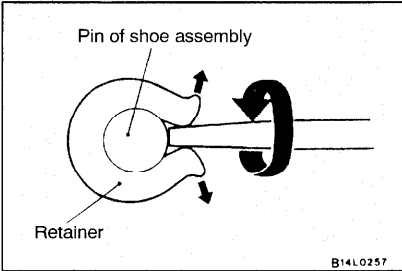
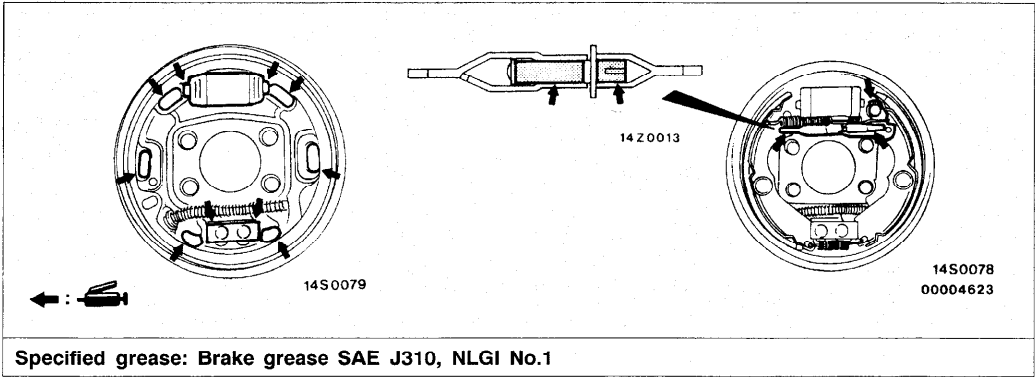

REMOVAL SERVICE POINT

◀A▶ RETAINER REMOVAL

Use a flat-tipped screwdriver or the like to open up the retainer joint, and remove retainer.

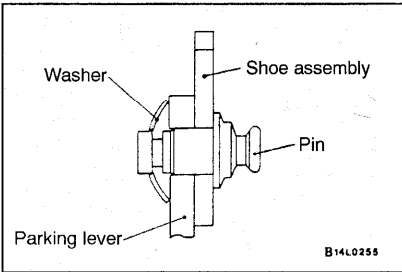

INSTALLATION SERVICE POINTS

▶A▶ WAVE WASHER INSTALLATION

Install the washer in the direction shown in the illustration.

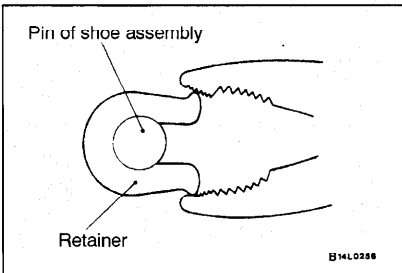

▶B▶ RETAINER INSTALLATION

Use pliers or the like to install the retainer or the pin positively.

**WHEEL CYLINDER
DISASSEMBLY AND REASSEMBLY**

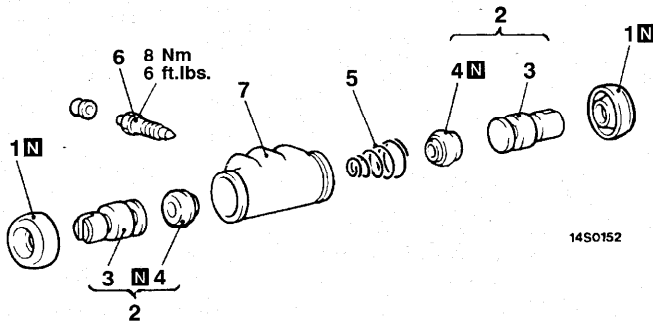

Brake fluid: DOT3 or DOT4

Grease: Repair kit grease

Wheel cylinder repair kit

Disassembly steps

1. Boots
2. Piston assembly
3. Pistons
4. Piston cups

5. Spring
6. Bleeder
7. Wheel cylinder body



REASSEMBLY SERVICE POINT

▶A◀ PISTON CUP/PISTON REASSEMBLY

- (1) Use alcohol or specified brake fluid to clean the wheel cylinder and the piston.
- (2) Apply the specified brake fluid to the piston cups and the special tool.

Specified brake fluid: DOT3 or DOT4

- (3) Set the piston cup on the special tool with the lip of the cup facing up, fit the cup onto the special tool, and then slide it down the outside of the tool into the piston groove.

Caution

In order to keep the piston cup from becoming twisted or slanted, slide the piston cup down the tool slowly and carefully, without stopping.

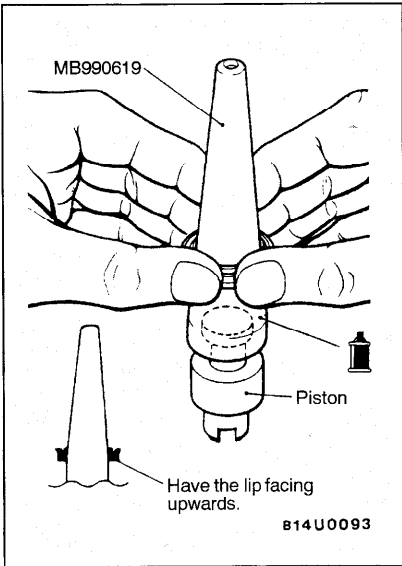

INSPECTION

Check the piston and wheel cylinder walls for rust or damage, and if there is any abnormality, replace the entire wheel cylinder assembly.

PROPORTIONING VALVE

REMOVAL AND INSTALLATION

Pre-removal Operation

- Brake Fluid Draining
- Air Intake Hose Removal

Post-installation Operation

- Brake Fluid Supplying
- Brake Line Bleeding (Refer to P.35A-11.)
- Air Intake Hose Installation

Flared brake line nuts



15 Nm
11 ft.lbs.

14X0343

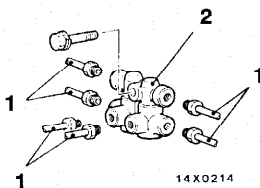

14X0214

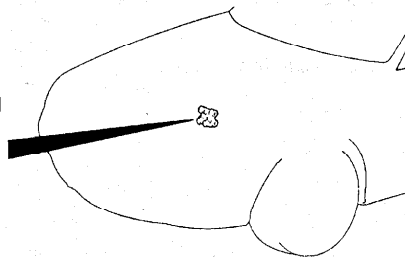

14X0146
00004624

Removal steps

- ▶A◀
1. Brake pipe
 2. Proportioning valve
 3. Bracket

INSTALLATION SERVICE POINT

▶A◀ BRAKE PIPE CONNECTION

Connect the pipes to the hydraulic unit as shown in the illustration.

1. Proportioning valve – Rear brake (L.H.)
2. Proportioning valve – Rear brake (R.H.)
3. Proportioning valve – Front brake (R.H.)
4. Proportioning valve – Front brake (L.H.)
5. Proportioning valve – Master cylinder (secondary)
6. Proportioning valve – Master cylinder (primary)

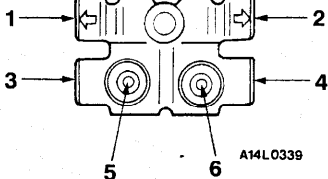

A14L0339